

# SKS 8-NS35 - Shield connection clamp

3240216

<https://www.phoenixcontact.com/in/products/3240216>

Please be informed that the data shown in this PDF document is generated from our Online Catalog. Please find the complete data in the user documentation. Our General Terms of Use for Downloads are valid.

Shield connection terminal block, for applying the shield to busbars



## Commercial Data

Item number	3240216
Packing unit	10 pc
Minimum order quantity	10 pc
Sales Key	BE7
Product Key	BE7523
Catalog Page	Page 569 (C-3-2019)
GTIN	4046356458870
Weight per Piece (including packing)	26.669 g
Weight per Piece (excluding packing)	24.69 g
Customs tariff number	85369010
Country of origin	DE

# SKS 8-NS35 - Shield connection clamp

3240216

<https://www.phoenixcontact.com/in/products/3240216>

## Technical Data

### Product properties

Product type	Shield connection clamp
Pitch	12.4 mm
Number of connections	1
Number of rows	1

### Electrical properties

Maximum power dissipation for nominal condition	0.77 W
---	--------

### Connection data

Grounding foot	Yes
Screw thread	M3,5
Tightening torque	1 ... 1.2 Nm
Conductor cross section rigid	3 mm <sup>2</sup> ... 8 mm <sup>2</sup>
Cross section AWG	12 ... 8 (converted acc. to IEC)
Conductor cross section flexible	3 mm <sup>2</sup> ... 8 mm <sup>2</sup>
Conductor cross section, flexible [AWG]	12 ... 8 (converted acc. to IEC)

### Dimensions

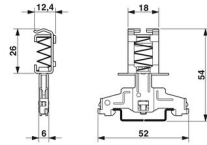
Dimensional drawing	
Width	12.5 mm
Height	50.7 mm
Height NS 35/15	61.5 mm
Height NS 35/7,5	54 mm
Height	2.12 "
Length	53.2 mm
Pitch	12.4 mm

### Material specifications

Color	silver
Material	Steel

### Cable/line

External cable diameter	3 mm ... 8 mm
-------------------------	---------------

### Mechanical properties

Mechanical data

# SKS 8-NS35 - Shield connection clamp



3240216

<https://www.phoenixcontact.com/in/products/3240216>

Open side panel	No
-----------------	----

## Mechanical tests

### Mechanical strength

Result	Test passed
--------	-------------

## Mounting

Mounting type	NS 35/7,5
	NS 35/15

# SKS 8-NS35 - Shield connection clamp

3240216

<https://www.phoenixcontact.com/in/products/3240216>



## Drawings

Dimensional drawing

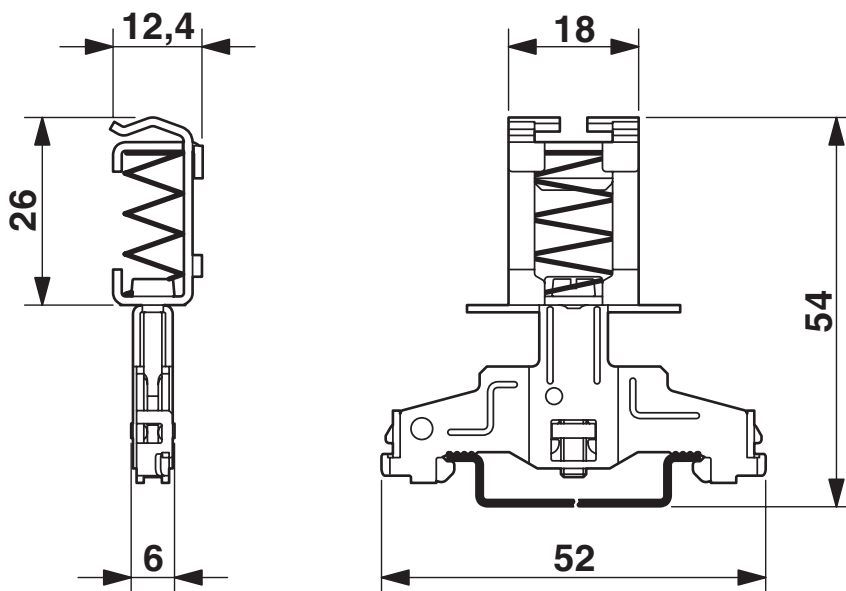

# SKS 8-NS35 - Shield connection clamp



3240216

<https://www.phoenixcontact.com/in/products/3240216>

## Classifications

### ECLASS

ECLASS-11.0	27141150
ECLASS-12.0	27141150
ECLASS-13.0	27250309

### ETIM

ETIM 8.0	EC002020
----------	----------

### UNSPSC

UNSPSC 21.0	39121400
-------------	----------

# SKS 8-NS35 - Shield connection clamp



3240216

<https://www.phoenixcontact.com/in/products/3240216>

## Environmental Product Compliance

China RoHS	Environmentally friendly use period: unlimited = EFUP-e
	No hazardous substances above threshold values

Phoenix Contact 2023 © - all rights reserved  
<https://www.phoenixcontact.com>

PHOENIX CONTACT (I) Pvt. Ltd.  
A-58/2, Okhla Industrial Area, Phase - II, New Delhi-110 020

+91.1275.71420  
[info@phoenixcontact.co.in](mailto:info@phoenixcontact.co.in)