

KEL 16/2 - Sealing frame

3063015

<https://www.phoenixcontact.com/in/products/3063015>



Please be informed that the data shown in this PDF document is generated from our online catalog. Please find the complete data in the user documentation. Our general terms of use for downloads are valid.

Sealing frame, material: PA, color: black, length: 120 mm, width: 58 mm, height: 17 mm



Product description

KEL sealing sleeves, small

Commercial data

Item number	3063015
Packing unit	10 pc
Minimum order quantity	1 pc
Product key	BF7CAX
Catalog page	Page 685 (CL-2009)
GTIN	4046356300742
Weight per piece (including packing)	94.31 g
Weight per piece (excluding packing)	94.31 g
Country of origin	DE

KEL 16/2 - Sealing frame

3063015

<https://www.phoenixcontact.com/in/products/3063015>

Technical data

Product properties

Product type	Frame for cable sleeves
--------------	-------------------------

Dimensions

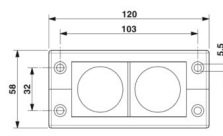
Dimensional drawing	
Width	58 mm
Height	17 mm
Length	120 mm
Drill hole distance, horizontal	32 mm
Drill hole distance, vertical	103 mm
Hole diameter	5.5 mm

Installation dimensions

Width of the assembly cutout	35 mm
Length of the assembly cutout	86 mm

Material specifications

Material	PA
Flammability rating according to UL 94	V0

Environmental and real-life conditions

Ambient conditions

Ambient temperature (operation)	-20 °C ... 80 °C
---------------------------------	------------------

KEL 16/2 - Sealing frame

3063015

<https://www.phoenixcontact.com/in/products/3063015>



Drawings

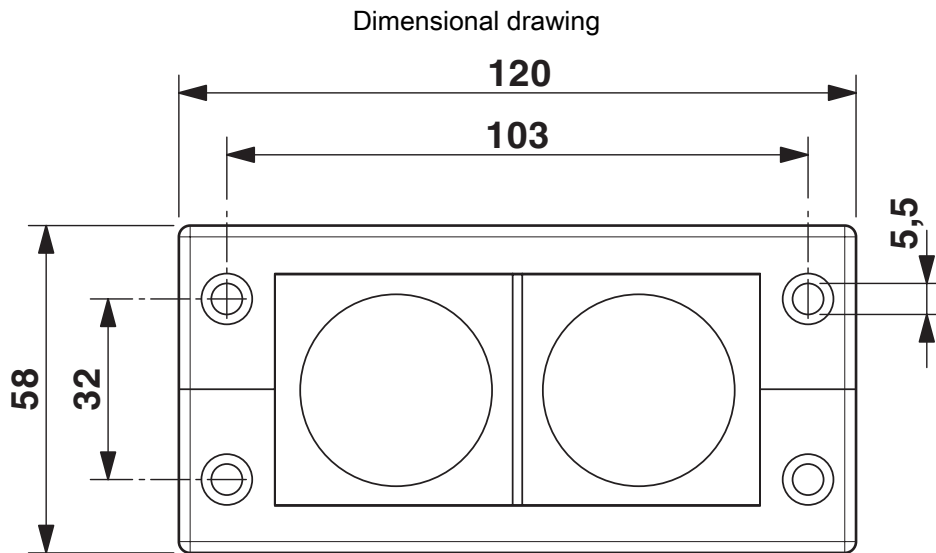

KEL 16/2 - Sealing frame

3063015

<https://www.phoenixcontact.com/in/products/3063015>



Classifications

ECLASS

ECLASS-11.0	27142421
ECLASS-13.0	27142421

KEL 16/2 - Sealing frame

3063015

<https://www.phoenixcontact.com/in/products/3063015>



Environmental product compliance

EU REACH SVHC

REACH candidate substance (CAS No.)	
-------------------------------------	--

	No substance above 0.1 wt%
--	----------------------------

Phoenix Contact 2024 © - all rights reserved

<https://www.phoenixcontact.com>

PHOENIX CONTACT (I) Pvt. Ltd.

A-58/2, Okhla Industrial Area, Phase - II, New Delhi-110 020

+91.1275.71420

info@phoenixcontact.co.in