

# QUINT-PS-3X400-500AC/24DC/10 - Power supply unit



2938617

<https://www.phoenixcontact.com/in/products/2938617>

Please be informed that the data shown in this PDF document is generated from our online catalog. Please find the complete data in the user documentation. Our general terms of use for downloads are valid.



DIN rail power supply unit 24 V DC/10 A, primary-switched, 3-phase.  
Please use the following item in new systems: 2904621

## Product description

QUINT POWER power supply units for plant and special engineering reliably start heavy loads with high inrush currents using the POWER BOOST. Thanks to the wide-range input and extensive package of approvals, they can be used in all sectors of industry the world over. The switching output or floating relay contact are used for remote diagnostics.

## Commercial data

Item number	2938617
Packing unit	1 pc
Minimum order quantity	1 pc
Sales key	CMP
Product key	CMPP33
Catalog page	Page 483 (IF-2007)
GTIN	4017918908379
Weight per piece (including packing)	1,535.622 g
Weight per piece (excluding packing)	1,100 g
Customs tariff number	85044030
Country of origin	TH

## Technical data

### Input data

#### AC operation

Nominal input voltage range	3x 400 V AC ... 500 V AC
Input voltage range	3x 320 V AC ... 575 V AC (for all three phases) 450 V DC ... 800 V DC
Input voltage range AC	3x 320 V AC ... 575 V AC (for all three phases)
Input voltage range DC	450 V DC ... 800 V DC
Voltage type of supply voltage	AC/DC
Inrush current	< 15 A (typical)
Inrush current integral ( $I^2t$ )	4 A <sup>2</sup> s
AC frequency range	45 Hz ... 65 Hz
Frequency range DC	0 Hz
Mains buffering time	> 40 ms (400 V AC) > 40 ms (480 V AC)
Current consumption	approx. 3x 0.63 A (400 V AC) 3x 0.57 A (480 V AC)
Nominal power consumption	280 W
Protective circuit	Transient surge protection; Varistor
Typical response time	< 1 s
Input fuse	5 A (slow-blow, internal)
Permissible DC backup fuse	DC: Connect a suitable fuse upstream
Recommended breaker for input protection	3x 6 A ... 16 A (Characteristics B, C, D, K)
Discharge current to PE	< 3.5 mA

### Output data

Efficiency	> 90 %
Nominal output voltage	24 V DC $\pm$ 1 %
Setting range of the output voltage ( $U_{Set}$ )	22.5 V ... 28.5 V
Nominal output current ( $I_N$ )	10 A (up to 60 °C)
POWER BOOST ( $I_{Boost}$ )	15 A
Derating	60 °C ... 70 °C (2.5 %/K)
Feedback voltage resistance	35 V DC
Active current limitation	ca. $I_{BOOST} = 15$ A (for short-circuit)
Control deviation	< 1 % (change in load, static 10 % ... 90 %) < 2 % (change in load, dynamic 10 % ... 90 %) < 0.1 % (change in input voltage $\pm$ 10 %)
Residual ripple	< 20 mV <sub>PP</sub> (with nominal values)
Output power	240 W
Peak switching voltages nominal load	< 100 mV <sub>PP</sub> (20 MHz)
Maximum no-load power dissipation	< 4 W
Power loss nominal load max.	< 28 W

# QUINT-PS-3X400-500AC/24DC/10 - Power supply unit



2938617

<https://www.phoenixcontact.com/in/products/2938617>

Rise time	< 2 ms ( $U_{OUT}$ (10 % ... 90 %))
Connection in parallel	yes, for redundancy and increased capacity
Connection in series	yes

## Signal: DC OK active

Output description	$U_{OUT} > 0.9 \times U_N$ : High signal
Maximum switching voltage	$\leq 24$ V
Output voltage	+ 24 V DC (Signal)
Maximum inrush current	$\leq 40$ mA
Continuous load current	$\leq 40$ mA

## Signal: DC OK floating

Output description	Relay contact, $U_{OUT} > 0.9 \times U_N$ : Contact closed
Maximum switching voltage	$\leq 30$ V AC/DC
Maximum inrush current	$\leq 1$ A
Continuous load current	$\leq 1$ A

## Connection data

### Input

Connection method	Screw connection
Conductor cross section, rigid min.	0.2 mm <sup>2</sup>
Conductor cross section, rigid max.	2.5 mm <sup>2</sup>
Conductor cross section flexible min.	0.2 mm <sup>2</sup>
Conductor cross section flexible max.	2.5 mm <sup>2</sup>
Conductor cross section AWG min.	24
Conductor cross section AWG max.	12
Stripping length	8 mm
Screw thread	M3
Tightening torque, min	0.5 Nm
Tightening torque max	0.6 Nm

### Output

Connection method	Screw connection
Conductor cross section, rigid min.	0.2 mm <sup>2</sup>
Conductor cross section, rigid max.	2.5 mm <sup>2</sup>
Conductor cross section flexible min.	0.2 mm <sup>2</sup>
Conductor cross section flexible max.	2.5 mm <sup>2</sup>
Conductor cross section AWG min.	24
Conductor cross section AWG max.	12
Stripping length	8 mm
Screw thread	M3
Tightening torque, min	0.5 Nm
Tightening torque max	0.6 Nm

### Signal

# QUINT-PS-3X400-500AC/24DC/10 - Power supply unit



2938617

<https://www.phoenixcontact.com/in/products/2938617>

Conductor cross section, rigid min.	0.2 mm <sup>2</sup>
Conductor cross section, rigid max.	2.5 mm <sup>2</sup>
Conductor cross section flexible min.	0.2 mm <sup>2</sup>
Conductor cross section flexible max.	2.5 mm <sup>2</sup>
Conductor cross section AWG min.	24
Conductor cross section AWG max.	12
Screw thread	M3
Tightening torque, min	0.5 Nm
Tightening torque max	0.6 Nm

## Signaling

Types of signaling	LED
	Active switching output
	Relay contact
Operating voltage display	Green LED

### Signal output: DC OK active

Status display	"DC OK" LED green
Note on status display	$U_{OUT} < 0.9 \times U_N$ : LED flashing

### Signal output: DC OK floating

Status display	"DC OK" LED green
----------------	-------------------

## Electrical properties

Insulation voltage input/output	4 kV AC (type test)
	2 kV AC (routine test)
Insulation voltage output / PE	500 V DC (routine test)
Insulation voltage input / PE	3.5 kV AC (type test)
	2 kV AC (routine test)

## Product properties

Product type	Power supply
Product family	QUINT POWER
MTBF (IEC 61709, SN 29500)	> 500000 h

### Data management status

Article revision	23
------------------	----

### Insulation characteristics

Protection class	I (with PE connection)
Degree of pollution	2

## Dimensions

Width	85 mm
Height	130 mm
Depth	125 mm

# QUINT-PS-3X400-500AC/24DC/10 - Power supply unit



2938617

<https://www.phoenixcontact.com/in/products/2938617>

## Installation dimensions

Installation distance right/left	0 mm / 0 mm
Installation distance top/bottom	50 mm / 50 mm

## Alternative assembly

Width	122 mm
Height	130 mm
Depth	88 mm

## Mounting

Assembly note	alignable: horizontally 0 mm, vertically 50 mm
Mounting position	horizontal DIN rail NS 35, EN 60715

## Material specifications

Housing material	Metal
Type of housing	AluNox (AlMg1)

## Environmental and real-life conditions

### Ambient conditions

Degree of protection	IP20
Ambient temperature (operation)	-25 °C ... 70 °C (> 60 °C Derating: 2,5 %/K)
Ambient temperature (storage/transport)	-40 °C ... 85 °C
Max. permissible relative humidity (operation)	95 % (at 25 °C, non-condensing)
Shock	18 ms, 30g, in each space direction (according to IEC 60068-2-27)
Vibration (operation)	< 15 Hz, amplitude $\pm 2.5$ mm (according to IEC 60068-2-6) 15 Hz ... 150 Hz, 2.3g, 90 min.

## Standards and regulations

Standard – Limitation of mains harmonic currents	EN 61000-3-2
Standard - Electrical safety	EN 62368-1
Standard - Equipment safety	GS (tested safety)
Standard – Protection against shock currents, basic requirements for protective separation in electrical equipment	EN 62368-1
Standard – Safety extra-low voltage	EN 62368-1 (SELV) EN 60204 (PELV)
Standard - Safe isolation	DIN VDE 0100-410

### Overvoltage category

EN 62477-1	III
------------	-----

## Approvals

Shipbuilding approval	DNV GL (EMC A)
UL approvals	UL/C-UL listed UL 508 UL/C-UL Recognized UL 60950-1

	UL ANSI/ISA-12.12.01 Class I, Division 2, Groups A, B, C, D (Hazardous Location)
--	--

## EMC data

Low Voltage Directive	Conformance with Low Voltage Directive 2014/35/EC
EMC requirements for noise emission	EN 61000-6-3
	EN 61000-6-4
EMC requirements for noise immunity	EN 61000-6-1
	EN 61000-6-2
Electromagnetic compatibility	Conformance with EMC Directive 2014/30/EU
Noise emission	EN 55011 (EN 55022)

## Electrostatic discharge

Standards/regulations	EN 61000-4-2
Housing	Level 4

## Electrostatic discharge

Contact discharge	8 kV
Discharge in air	15 kV
Comments	Criterion B

## Electromagnetic HF field

Standards/regulations	EN 61000-4-3
-----------------------	--------------

## Electromagnetic HF field

Frequency range	80 MHz ... 2 GHz
Test field strength	10 V/m
Comments	Criterion A

## Fast transients (burst)

Standards/regulations	EN 61000-4-4
-----------------------	--------------

## Fast transients (burst)

Input	4 kV (level 4 - asymmetrical)
Output	2 kV (Level 3 - asymmetrical)
Signal	1 kV (Level 2 - asymmetrical)
Comments	Criterion B

## Surge voltage load (surge)

Standards/regulations	EN 61000-4-5
-----------------------	--------------

## Surge voltage load (surge)

Input	4 kV (inst. class 4 - asymmetrical: conductor to ground)
	2 kV (inst. class 4 -symmetrical: conductor to conductor)
Output	0.5 kV (level 1 - asymmetrical: conductor to ground)
	0.5 kV (level 1 - symmetrical: conductor to conductor)
Signal	1 kV (level 2 - asymmetrical: conductor to ground)
Comments	Criterion B

# QUINT-PS-3X400-500AC/24DC/10 - Power supply unit



2938617

<https://www.phoenixcontact.com/in/products/2938617>

## Conducted interference

Standards/regulations	EN 61000-4-6
-----------------------	--------------

## Conducted interference

I/O/S	Level 3 - asymmetrical
Frequency range	0.15 MHz ... 80 MHz
Comments	Criterion A
Voltage	10 V

## Voltage dips

Standards/regulations	EN 61000-4-11
-----------------------	---------------

## Emitted interference

Standards/regulations	EN 61000-6-3
Radio interference voltage in acc. with EN 55011	EN 55011 (EN 55022) Class B, area of application: Industry and residential
Emitted radio interference in acc. with EN 55011	EN 55011 (EN 55022) Class B, area of application: Industry and residential

Drawings

Block diagram

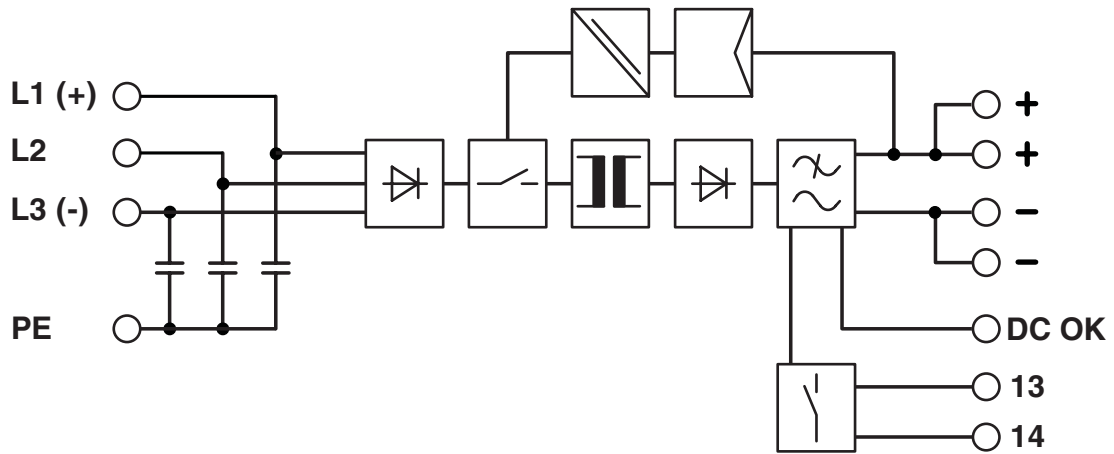



2938617

<https://www.phoenixcontact.com/in/products/2938617>

## Approvals

To download certificates, visit the product detail page: <https://www.phoenixcontact.com/in/products/2938617>



**cUL Recognized**  
Approval ID: E211944



**UL Recognized**  
Approval ID: E211944



**EAC**  
Approval ID: EAC-Zulassung



**EAC**  
Approval ID: RU S-DE.BL08.W.00764



**UL Listed**  
Approval ID: FILE E 123528



**cUL Listed**  
Approval ID: FILE E 123528



**IECEE CB Scheme**  
Approval ID: DE/PTZ/0077



**cUL Listed**  
Approval ID: E199827



**UL Listed**  
Approval ID: E199827

**cULus Recognized**

**cULus Listed**

**cULus Listed**

# QUINT-PS-3X400-500AC/24DC/10 - Power supply unit



2938617

<https://www.phoenixcontact.com/in/products/2938617>

# QUINT-PS-3X400-500AC/24DC/10 - Power supply unit



2938617

<https://www.phoenixcontact.com/in/products/2938617>

## Classifications

### ECLASS

ECLASS-11.0

27040701

### ETIM

ETIM 8.0

EC002540

### UNSPSC

UNSPSC 21.0

39121000

2938617

<https://www.phoenixcontact.com/in/products/2938617>

## Environmental product compliance

### EU RoHS

Fulfills EU RoHS substance requirements	Yes
Exemption	7(a), 7(c)-I

### China RoHS

Environment friendly use period (EFUP)	EFUP-25
	An article-related China RoHS declaration table can be found in the download area for the respective article under "Manufacturer declaration". For all articles with EFUP-E, no China RoHS declaration table issued and required.

### EU REACH SVHC

REACH candidate substance (CAS No.)	Lead(CAS: 7439-92-1)
-------------------------------------	----------------------

### EF3.0 Climate Change

CO2e kg	45.811 kg CO2e
---------	----------------

# QUINT-PS-3X400-500AC/24DC/10 - Power supply unit



2938617

<https://www.phoenixcontact.com/in/products/2938617>

## Accessories

### QUINT-PS-ADAPTERS7/2 - Mounting adapter

2938206

<https://www.phoenixcontact.com/in/products/2938206>

Assembly adapter for QUINT POWER 10A on S7-300 rail



---

### UWA 182/52 - Mounting adapter

2938235

<https://www.phoenixcontact.com/in/products/2938235>

Universal wall adapter for securely mounting the device in the event of strong vibrations. The device is screwed directly onto the mounting surface. The universal wall adapter is attached on the top/bottom.



# QUINT-PS-3X400-500AC/24DC/10 - Power supply unit



2938617

<https://www.phoenixcontact.com/in/products/2938617>

## UTA 107 - DIN rail adapter

2853983

<https://www.phoenixcontact.com/in/products/2853983>

Universal DIN rail adapter, for screwing on switchgear



---

## PLT-SEC-T3-3S-230-FM - Type 3 surge protection device

2905230

<https://www.phoenixcontact.com/in/products/2905230>

Plug-in device protection, according to type 3/class III, for 3-phase power supply networks with separate N and PE (5-conductor system: L1, L2, L3, N, PE), with integrated surge-proof fuse and remote indication contact.

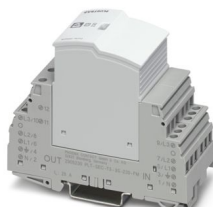

# QUINT-PS-3X400-500AC/24DC/10 - Power supply unit



2938617

<https://www.phoenixcontact.com/in/products/2938617>

## PLT-SEC-T3-24-FM-UT - Type 3 surge protection device

2907916

<https://www.phoenixcontact.com/in/products/2907916>



Type 3 surge protection, consisting of protective plug and base element, with integrated status indicator and remote signaling for single-phase power supply networks. Nominal voltage: 24 V AC/DC

---

Phoenix Contact 2024 © - all rights reserved

<https://www.phoenixcontact.com>

PHOENIX CONTACT (I) Pvt. Ltd.

A-58/2, Okhla Industrial Area, Phase - II, New Delhi-110 020

+91.1275.71420

[info@phoenixcontact.co.in](mailto:info@phoenixcontact.co.in)