

VAL-MB-T1/T2 1500DC-PV/2+V - Lightning/surge arrester type 1/2



2905641

<https://www.phoenixcontact.com/in/products/2905641>

Please be informed that the data shown in this PDF document is generated from our Online Catalog. Please find the complete data in the user documentation. Our General Terms of Use for Downloads are valid.



Lightning current arrester/surge protective device for 2-pos. isolated and grounded 1500 V DC PV systems, for DIN rail mounting, temperature-monitored protective elements, status message on the module.

Your advantages

- Space-saving installation, thanks to the compact design
- Double terminal block for safe and easy equipotential bonding connection
- Screw shafts with raised domes to ensure safe working
- Main connections with extended insertion funnels for increased resistance to creepage
- Visual display for checking the status directly on the device

Commercial Data

Item number	2905641
Packing unit	1 pc
Minimum order quantity	1 pc
Sales Key	CL1
Product Key	CL1231
Catalog Page	Page 51 (C-4-2019)
GTIN	4046356984393
Weight per Piece (including packing)	525.8 g
Weight per Piece (excluding packing)	488.61 g
Customs tariff number	85354000
Country of origin	DE

VAL-MB-T1/T2 1500DC-PV/2+V - Lightning/surge arrester type 1/2



2905641

<https://www.phoenixcontact.com/in/products/2905641>

Technical Data

Notes

General

Note	The product is also suitable for use in photovoltaic systems with max. short-circuit current $I_{SCPV} = 15 \text{ kA}$ (in accordance with EN 50539-11: 2013).
------	---

Product properties

IEC test classification	PV I / II PV T1 / T2
EN type	T1 / T2
IEC power supply system	DC
Type	DIN rail module, one-piece
Product type	PV arrester
Product family	VALVETRAB MB
Installation location	Interior
Installation location of the disconnect device	Internal
Accessibility	Accessible
Connection configuration	Y configuration
SPD failure behavior	OCFM (Open-Circuit Failure Mode)
Surge protection fault message	optical

Insulation characteristics

Pollution degree	2
------------------	---

Connection data

Connection method	Screw connection
Screw thread	M5
Tightening torque	3 Nm
Stripping length	16 mm
Conductor cross section flexible	2.5 mm ² ... 35 mm ²
Conductor cross section AWG	14 ... 2

Dimensions

Dimensional drawing	
Width	71.2 mm
Height	120 mm
Depth	65.5 mm (incl. DIN rail 7.5 mm)

VAL-MB-T1/T2 1500DC-PV/2+V - Lightning/surge arrester type 1/2



2905641

<https://www.phoenixcontact.com/in/products/2905641>

Horizontal pitch	4 Div.
------------------	--------

Material specifications

Color	traffic grey A RAL 7042
Flammability rating according to UL 94	V-0
Insulating material	PA 6.6
	PBT
Housing material	PA 6.6

Mechanical properties

Mechanical data

Open side panel	No
-----------------	----

Protective circuit

Mode of protection	(L+) - (L-)
	(L+) - PE
	(L-) - PE
Direction of action	(L+)-PE & (L-)-PE & (L+)-(L-)
Rated load current I_L	50 A
Residual current I_{PE}	$\leq 100 \mu\text{A DC}$
	$\leq 540 \mu\text{A AC}$
Standby power consumption P_C	$\leq 150 \text{ mVA}$
Nominal discharge current I_n (8/20) μs	20 kA
Maximum discharge current I_{max} (8/20) μs	40 kA
Impulse discharge current (10/350) μs , charge	3.125 As
Impulse discharge current (10/350) μs , specific energy	9.77 kJ/ Ω
Impulse discharge current (10/350) μs , peak value I_{imp}	6.25 kA
Total discharge current I_{total} (8/20) μs	40 kA
Total discharge current I_{total} (10/350) μs	12.5 kA
Voltage protection level U_p	$\leq 4.5 \text{ kV}$
Residual voltage U_{res}	$\leq 4.5 \text{ kV}$ (at I_n)
	$\leq 3.3 \text{ kV}$ (at 3 kA)
	$\leq 3.6 \text{ kV}$ (at 6.25 kA)
	$\leq 3.8 \text{ kV}$ (at 10 kA)
	$\leq 4.2 \text{ kV}$ (at 15 kA)
	$\leq 5.4 \text{ kV}$ (at 40 kA)
Response time t_A	$\leq 25 \text{ ns}$

PV protective circuit

Connection configuration	Y configuration
SPD failure behavior	OCFM (Open-Circuit Failure Mode)

Protective circuit DC voltage side (DC)

VAL-MB-T1/T2 1500DC-PV/2+V - Lightning/surge arrester type 1/2



2905641

<https://www.phoenixcontact.com/in/products/2905641>

Open circuit voltage U_{OCSTC}	≤ 1250 V DC
Maximum discharge current I_{max} (8/20) μs	40 kA
Response time t_A	≤ 25 ns
Impulse discharge current (10/350) μs , charge	3.125 As
Impulse discharge current (10/350) μs , specific energy	9.77 kJ/ Ω
Impulse discharge current (10/350) μs , peak value I_{imp}	6.25 kA
Total discharge current I_{total} (8/20) μs	40 kA
Total discharge current I_{total} (10/350) μs	12.5 kA
Insulation resistance R_{iso}	> 5 G Ω (at 500 V DC)
Nominal discharge current I_n (8/20) μs	20 kA
Rated load current I_L	50 A
Continuous operating current I_{CPV}	< 100 μA
Maximum continuous operating voltage U_{CPV}	1500 V DC
Short-circuit current rating I_{SCPV}	2000 A
Residual voltage U_{res}	≤ 4.5 kV (at I_n) ≤ 3.3 kV (at 3 kA) ≤ 3.6 kV (at 6.25 kA) ≤ 3.8 kV (at 10 kA) ≤ 4.2 kV (at 15 kA) ≤ 5.4 kV (at 40 kA)
Residual current I_{PE}	≤ 100 μA DC ≤ 540 μA AC
Voltage protection level U_p	≤ 4.5 kV
Standby power consumption P_C	≤ 150 mVA

Environmental and real-life conditions

Ambient conditions

Degree of protection	IP20 (only when all terminal points are used)
Ambient temperature (operation)	-40 °C ... 80 °C
Ambient temperature (storage/transport)	-40 °C ... 80 °C
Altitude	≤ 6000 m (amsl (above mean sea level))
Permissible humidity (operation)	5 % ... 95 %
Shock (operation)	50g (Half-sine / 11 ms / 3x $\pm X$, $\pm Y$, $\pm Z$)
Vibration (operation)	5g (5 - 500 Hz/2.5 h/X, Y, Z)

Standards and regulations

Standards/specifications	EN 61643-31
Standards/specifications	IEC 61643-31

Mounting

Mounting type	DIN rail: 35 mm
---------------	-----------------

VAL-MB-T1/T2 1500DC-PV/2+V - Lightning/surge arrester type 1/2

2905641

<https://www.phoenixcontact.com/in/products/2905641>

Drawings

Circuit diagram

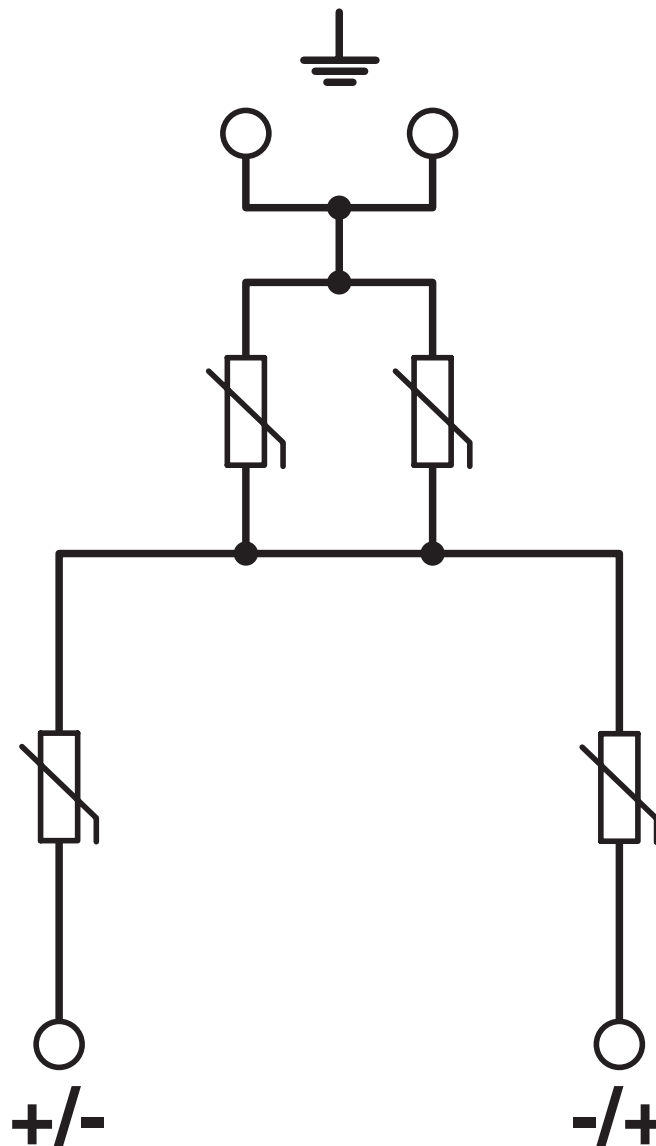

VAL-MB-T1/T2 1500DC-PV/2+V - Lightning/surge arrester type 1/2



2905641

<https://www.phoenixcontact.com/in/products/2905641>

Dimensional drawing

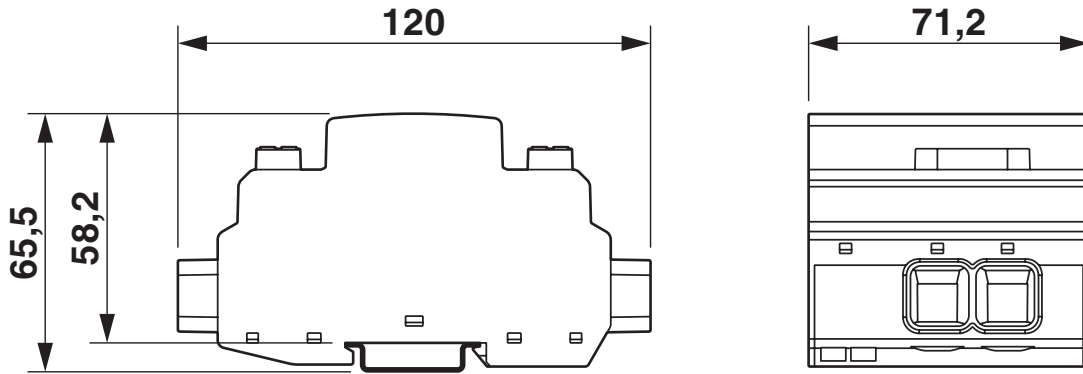

VAL-MB-T1/T2 1500DC-PV/2+V - Lightning/surge arrester type 1/2



2905641

<https://www.phoenixcontact.com/in/products/2905641>

Approvals



IECEE CB Scheme
Approval ID: NL-81007



KEMA-KEUR
Approval ID: 71-127691

VAL-MB-T1/T2 1500DC-PV/2+V - Lightning/surge arrester type 1/2



2905641

<https://www.phoenixcontact.com/in/products/2905641>

Classifications

ECLASS

ECLASS-11.0	27130802
-------------	----------

ETIM

ETIM 8.0	EC000381
----------	----------

UNSPSC

UNSPSC 21.0	39121600
-------------	----------

VAL-MB-T1/T2 1500DC-PV/2+V - Lightning/surge arrester type 1/2



2905641

<https://www.phoenixcontact.com/in/products/2905641>

Environmental Product Compliance

China RoHS	Environmentally friendly use period: unlimited = EFUP-e
	No hazardous substances above threshold values

VAL-MB-T1/T2 1500DC-PV/2+V - Lightning/surge arrester type 1/2



2905641

<https://www.phoenixcontact.com/in/products/2905641>

Accessories

X-PEN 0,35 - Marker pen

0811228

<https://www.phoenixcontact.com/in/products/0811228>



Marker pen without ink cartridge, for manual labeling of markers, labeling extremely wipe-proof, line thickness 0.35 mm

ATP-QTTCB - Partition plate

3206238

<https://www.phoenixcontact.com/in/products/3206238>

Partition plate, length: 102 mm, width: 2 mm, height: 54 mm, color: gray



Phoenix Contact 2023 © - all rights reserved

<https://www.phoenixcontact.com>

PHOENIX CONTACT (I) Pvt. Ltd.

A-58/2, Okhla Industrial Area, Phase - II, New Delhi-110 020

+91.1275.71420

info@phoenixcontact.co.in