

QUINT-PS/1AC/24DC/ 5 - Power supply unit



2866750

<https://www.phoenixcontact.com/in/products/2866750>

Please be informed that the data shown in this PDF document is generated from our Online Catalog. Please find the complete data in the user documentation. Our General Terms of Use for Downloads are valid.



Primary-switched power supply unit QUINT POWER, Pluggable screw connection, DIN rail mounting, SFB Technology (Selective Fuse Breaking), input: 1-phase, output: 24 V DC / 5 A

Product Description

QUINT POWER power supplies with maximum functionality

QUINT POWER circuit breakers magnetically and therefore quickly trip at six times the nominal current, for selective and therefore cost-effective system protection. The high level of system availability is additionally ensured, thanks to preventive function monitoring, as it reports critical operating states before errors occur.

Reliable starting of heavy loads takes place via the static power reserve POWER BOOST. Thanks to the adjustable voltage, all ranges between 5 V DC ... 56 V DC are covered.

Your advantages

- Reliable starting of difficult loads with the static POWER BOOST power reserve with up to 1.5 times the nominal current permanently
- Fast tripping of standard circuit breakers with dynamic power reserve SFB (selective fuse breaking) technology with up to 6 times the nominal current for 12 ms
- For superior system availability
- Preventive function monitoring

Commercial Data

Item number	2866750
Packing unit	1 pc
Minimum order quantity	1 pc
Sales Key	CMP
Product Key	CMPQ13
Catalog Page	Page 158 (C-6-2015)
GTIN	4046356113786
Weight per Piece (including packing)	1,071.1 g
Weight per Piece (excluding packing)	1,022 g
Customs tariff number	85044083
Country of origin	TH

Technical Data

Input data

AC operation

Nominal input voltage range	100 V AC ... 240 V AC
Input voltage range	85 V AC ... 264 V AC
	110 V DC ... 350 V DC (typ. 90 V DC (UL 508: ≤ 300 V DC))
Electric strength, max.	300 V AC
Voltage type of supply voltage	AC/DC
Inrush current	< 15 A
Inrush current integral (I^2t)	< 1 A ² s
AC frequency range	45 Hz ... 65 Hz
Frequency range DC	0 Hz
Mains buffering time	> 55 ms (120 V AC)
	> 55 ms (230 V AC)
Current consumption	1.2 A (120 V AC)
	0.6 A (230 V AC)
	1.3 A (110 V DC)
	0.6 A (220 V DC)
Nominal power consumption	145 VA
Protective circuit	Transient surge protection; Varistor
Power factor (cos phi)	0.94
Typical response time	< 0.15 s
Input fuse	5 A (slow-blow, internal)
Permissible backup fuse	B6 B10 B16 AC:
Permissible DC backup fuse	DC: Connect a suitable fuse upstream
Recommended breaker for input protection	6 A ... 16 A (AC: Characteristics B, C, D, K)
Discharge current to PE	< 3.5 mA

Output data

Efficiency	> 90 % (for 230 V AC and nominal values)
Output characteristic	U/I
Nominal output voltage	24 V DC ±1 %
Setting range of the output voltage (U_{Set})	18 V DC ... 29.5 V DC (> 24 V DC, constant capacity restricted)
Nominal output current (I_N)	5 A (-25 °C ... 60 °C, $U_{OUT} = 24$ V DC)
POWER BOOST (I_{Boost})	7.5 A (-25 °C ... 40 °C permanent, $U_{OUT} = 24$ V DC)
Selective Fuse Breaking (I_{SFB})	30 A (12 ms)
Magnetic circuit breaker tripping	B2 / B4 / C2
Derating	60 °C ... 70 °C (2.5%/K)
Feedback voltage resistance	≤ 35 V DC
Protection against overvoltage at the output (OVP)	< 35 V DC
Control deviation	< 1 % (change in load, static 10 % ... 90 %)
	< 2 % (change in load, dynamic 10 % ... 90 %)

QUINT-PS/1AC/24DC/ 5 - Power supply unit



2866750

<https://www.phoenixcontact.com/in/products/2866750>

	< 0.1 % (change in input voltage ± 10 %)
Residual ripple	< 40 mV _{PP} (with nominal values)
Output power	120 W
Maximum no-load power dissipation	3 W
Power loss nominal load max.	15 W
Rise time	< 0.1 s (U_{OUT} (10 % ... 90 %))
Connection in parallel	yes, for redundancy and increased capacity
Connection in series	yes

Signal: DC OK active

Output description	$U_{OUT} > 0.9 \times U_N$: High signal
Switching voltage range	18 V DC ... 24 V DC
Maximum inrush current	≤ 20 mA (short-circuit-proof)
Continuous load current	≤ 20 mA

Signal: DC OK floating

Output description	Relay contact, $U_{OUT} > 0.9 \times U_N$: Contact closed
Maximum switching voltage	30 V AC
	24 V DC
Maximum inrush current	0.5 A
	1 A
Continuous load current	≤ 1 A

Signal: POWER BOOST, active

Output description	$I_{OUT} < I_N$: High signal
Switching voltage range	18 V DC ... 24 V DC
Output voltage	+ 24 V DC
Maximum inrush current	20 mA (short-circuit-proof)
Continuous load current	≤ 20 mA

Connection data

Input

Connection method	Pluggable screw connection
Conductor cross section, rigid min.	0.2 mm ²
Conductor cross section, rigid max.	2.5 mm ²
Conductor cross section flexible min.	0.2 mm ²
Conductor cross section flexible max.	2.5 mm ²
Conductor cross section AWG min.	20
Conductor cross section AWG max.	12
Stripping length	7 mm
Screw thread	M3
Tightening torque, min	0.5 Nm
Tightening torque max	0.6 Nm

Output

QUINT-PS/1AC/24DC/ 5 - Power supply unit



2866750

<https://www.phoenixcontact.com/in/products/2866750>

Connection method	Pluggable screw connection
Conductor cross section, rigid min.	0.2 mm ²
Conductor cross section, rigid max.	2.5 mm ²
Conductor cross section flexible min.	0.2 mm ²
Conductor cross section flexible max.	2.5 mm ²
Conductor cross section AWG min.	20
Conductor cross section AWG max.	12
Stripping length	7 mm
Screw thread	M3
Tightening torque, min	0.5 Nm
Tightening torque max	0.6 Nm

Signal

Connection method	Pluggable screw connection
Conductor cross section, rigid min.	0.2 mm ²
Conductor cross section, rigid max.	2.5 mm ²
Conductor cross section flexible min.	0.2 mm ²
Conductor cross section flexible max.	2.5 mm ²
Conductor cross section AWG min.	20
Conductor cross section AWG max.	12
Screw thread	M3
Tightening torque, min	0.5 Nm
Tightening torque max	0.6 Nm

Signaling

Types of signaling	LED
	Active switching output
	Relay contact

Signal output: DC OK active

Status display	$U_{OUT} > 0.9 \times U_N$: "DC OK" LED green
Note on status display	$U_{OUT} < 0.9 \times U_N$: Flashing "DC OK" LED
	$I_{OUT} < I_N$: LED ON

Signal output: DC OK floating

Status display	$U_{OUT} > 0.9 \times U_N$: "DC OK" LED green
Note on status display	$U_{OUT} < 0.9 \times U_N$: Flashing "DC OK" LED

Signal output: POWER BOOST, active

Status display	$I_{OUT} > I_N$: LED "BOOST" yellow
----------------	--------------------------------------

Electrical properties

Number of phases	1.00
Insulation voltage input/output	4 kV AC (type test)
	2 kV AC (routine test)
Insulation voltage output / PE	500 V DC (routine test)

QUINT-PS/1AC/24DC/ 5 - Power supply unit



2866750

<https://www.phoenixcontact.com/in/products/2866750>

Insulation voltage input / PE	3.5 kV AC (type test)
	2 kV AC (routine test)

Product properties

Product type	Power supply
Product family	QUINT POWER
MTBF (IEC 61709, SN 29500)	> 1134000 h (25 °C)
	> 635000 h (40 °C)
	> 270000 h (60 °C)

Insulation characteristics

Protection class	I
Degree of pollution	2

Dimensions

Width	40 mm
Height	130 mm
Depth	125 mm

Alternative assembly

Width	122 mm
Height	130 mm
Depth	43 mm

Mounting

Mounting type	DIN rail mounting
Assembly instructions	alignable: $P_N \geq 50\%$, 5 mm horizontally, 15 mm next to active components, 50 mm vertically alignable: $P_N < 50\%$, 0 mm horizontally, 40 mm vertically top, 20 mm vertically bottom
Mounting position	horizontal DIN rail NS 35, EN 60715
With protective coating	No

Material specifications

Housing material	Metal
Hood version	Galvanized sheet steel, free from chrome (VI)
Side element version	Aluminum

Environmental and real-life conditions

Ambient conditions

Degree of protection	IP20
Ambient temperature (operation)	-25 °C ... 70 °C (> 60 °C Derating: 2,5 %/K)
Ambient temperature (storage/transport)	-40 °C ... 85 °C
Ambient temperature (start-up type tested)	-40 °C
Maximum altitude	5000 m
Climatic class	3K3 (in acc. with EN 60721)

QUINT-PS/1AC/24DC/ 5 - Power supply unit



2866750

<https://www.phoenixcontact.com/in/products/2866750>

Max. permissible relative humidity (operation)	≤ 95 % (at 25 °C, non-condensing)
Shock	18 ms, 30g, in each space direction (according to IEC 60068-2-27)
Vibration (operation)	< 15 Hz, amplitude ±2.5 mm (according to IEC 60068-2-6) 15 Hz ... 150 Hz, 2.3g, 90 min.

Standards and regulations

Rail applications	EN 50121-4 EN 50121-3-2
HART FSK Physical Layer Test Specification Compliance	Output voltage U_{Out} compliant
Standard – Limitation of mains harmonic currents	EN 61000-3-2
Standard - Electrical safety	IEC 61010-2-201 (SELV)
Standard - Equipment safety	BG (design tested)
Standard - Approval for medical use	IEC 60601-1, 2 x MOOP
Standard – Safety extra-low voltage	IEC 61010-1 (SELV) IEC 61010-2-201 (PELV)
Standard - Safe isolation	IEC 61010-2-201
Standard - safety for equipment for measurement, control, and laboratory use	IEC 61010-1
Approval - requirement of the semiconductor industry with regard to mains voltage dips	SEMI F47-0706 Compliance Certificate
DeviceNet approval	DeviceNet™ Power Supply Conformance Tested

Overvoltage category

EN 62477-1	III
------------	-----

Approvals

CSA	CAN/CSA-C22.2 No. 60950-1-07 CSA-C22.2 No. 107.1-01
Shipbuilding approval	DNV GL (EMC A), ABS, LR, RINA, NK, BV
SIQ	BG (type approved)
UL approvals	UL Listed UL 508 UL/C-UL Recognized UL 60950-1 UL ANSI/ISA-12.12.01 Class I, Division 2, Groups A, B, C, D (Hazardous Location)
DeviceNet approval	DeviceNet™ Power Supply Conformance Tested

EMC data

Low Voltage Directive	Conformance with Low Voltage Directive 2014/35/EC
EMC requirements for noise emission	EN 61000-6-3 EN 61000-6-4
EMC requirements for noise immunity	EN 61000-6-1 EN 61000-6-2
Electromagnetic compatibility	Conformance with EMC Directive 2014/30/EU
Noise emission	EN 55011 (EN 55022)

QUINT-PS/1AC/24DC/ 5 - Power supply unit



2866750

<https://www.phoenixcontact.com/in/products/2866750>

Electrostatic discharge

Standards/regulations	EN 61000-4-2
-----------------------	--------------

Electrostatic discharge

Contact discharge	8 kV (Test Level 4)
Discharge in air	15 kV (Test Level 4)
Comments	Criterion A

Electromagnetic HF field

Standards/regulations	EN 61000-4-3
-----------------------	--------------

Electromagnetic HF field

Frequency range	80 MHz ... 1 GHz
Test field strength	20 V/m (Test Level 3)
Frequency range	1 GHz ... 2 GHz
Test field strength	10 V/m (Test Level 3)
Frequency range	2 GHz ... 3 GHz
Test field strength	10 V/m (Test Level 3)
Comments	Criterion A

Fast transients (burst)

Standards/regulations	EN 61000-4-4
-----------------------	--------------

Fast transients (burst)

Input	4 kV (Test Level 4 - asymmetrical)
Output	2 kV (Test Level 3 - asymmetrical)
Signal	2 kV (Test Level 4 - asymmetrical)
Comments	Criterion A

Surge voltage load (surge)

Standards/regulations	EN 61000-4-5
Input	2 kV (Test Level 3 - symmetrical)
	4 kV (Test Level 4 - asymmetrical)
Output	1 kV (Test Level 2 - symmetrical)
	2 kV (Test Level 3 - asymmetrical)
Signal	1 kV (Test Level 2 - asymmetrical)
Comments	Criterion A

Conducted interference

Standards/regulations	EN 61000-4-6
-----------------------	--------------

Conducted interference

I/O/S	asymmetrical
Frequency range	0.15 MHz ... 80 MHz
Comments	Criterion A
Voltage	10 V (Test Level 3)

QUINT-PS/1AC/24DC/ 5 - Power supply unit



2866750

<https://www.phoenixcontact.com/in/products/2866750>

Emitted interference

Standards/regulations	EN 61000-6-3
Radio interference voltage in acc. with EN 55011	EN 55011 (EN 55022) Class B, area of application: Industry and residential
Emitted radio interference in acc. with EN 55011	EN 55011 (EN 55022) Class B, area of application: Industry and residential

Criteria

Criterion A	Normal operating behavior within the specified limits.
Criterion B	Temporary impairment to operational behavior that is corrected by the device itself.

QUINT-PS/1AC/24DC/ 5 - Power supply unit



2866750

<https://www.phoenixcontact.com/in/products/2866750>

Drawings

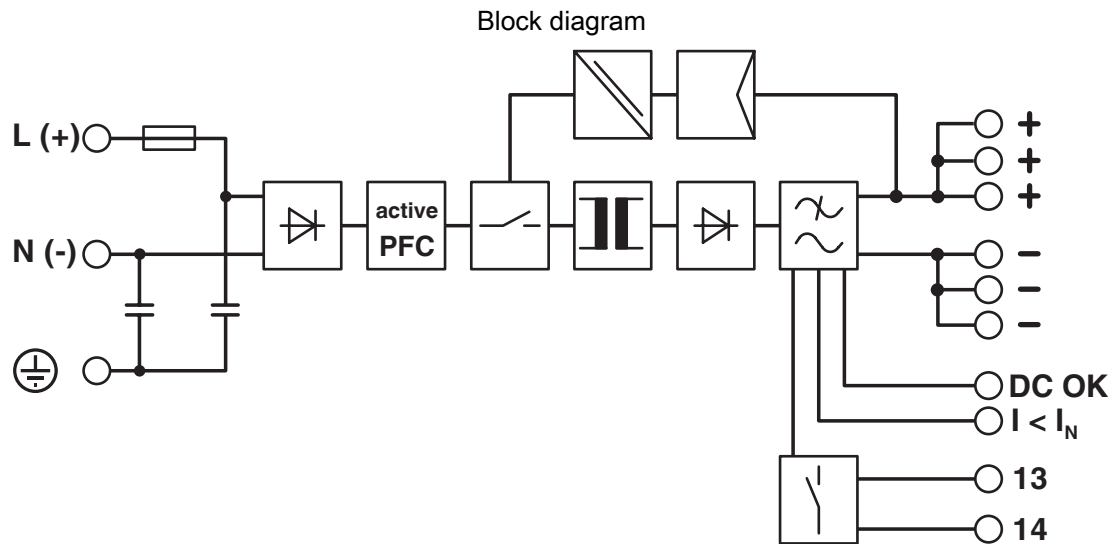

QUINT-PS/1AC/24DC/ 5 - Power supply unit



2866750

<https://www.phoenixcontact.com/in/products/2866750>

Approvals



cUL Recognized
Approval ID: FILE E 211944



UL Recognized
Approval ID: FILE E 211944



IECEE CB Scheme
Approval ID: SI-6188 A1



EAC
Approval ID: EAC-Zulassung



LR
Approval ID: LR22301698TA-02



NK
Approval ID: TA22564M



BV
Approval ID: 21004/C1 BV



EAC
Approval ID: EAC-Zulassung



UL Listed
Approval ID: FILE E 123528



RINA
Approval ID: ELE333522XG



Type approved
Approval ID: SI-SIQ BG 005/004



DeviceNet
Approval ID: 10825/05.01.2010

QUINT-PS/1AC/24DC/ 5 - Power supply unit



2866750

<https://www.phoenixcontact.com/in/products/2866750>



EAC

Approval ID: RU S-DE.BL08.W.00764



UL Recognized

Approval ID: FILE E 211944



IECEE CB Scheme

Approval ID: SI-6188 A1



cUL Recognized

Approval ID: FILE E 211944



UL Listed

Approval ID: FILE E 123528



BV

Approval ID: 21004/C1 BV



NK

Approval ID: TA22564M



RINA

Approval ID: ELE333522XG



LR

Approval ID: LR22301698TA-02



Type approved

Approval ID: SI-SIQ BG 005/004



EAC

Approval ID: RU S-DE.BL08.W.00764



EAC

Approval ID: RU S-DE.BL08.W.00764

QUINT-PS/1AC/24DC/ 5 - Power supply unit



2866750

<https://www.phoenixcontact.com/in/products/2866750>



EAC

Approval ID: RU S-DE.BL08.W.00764



cUL Listed

Approval ID: FILE E 199827



UL Listed

Approval ID: FILE E 199827



UL Listed

Approval ID: FILE E 199827



cUL Listed

Approval ID: FILE E 199827

QUINT-PS/1AC/24DC/ 5 - Power supply unit



2866750

<https://www.phoenixcontact.com/in/products/2866750>

Classifications

ECLASS

ECLASS-11.0	27040701
ECLASS-12.0	27040701
ECLASS-13.0	27040701

ETIM

ETIM 8.0	EC002540
----------	----------

UNSPSC

UNSPSC 21.0	39121000
-------------	----------

QUINT-PS/1AC/24DC/ 5 - Power supply unit



2866750

<https://www.phoenixcontact.com/in/products/2866750>

Environmental Product Compliance

REACH SVHC	Lead 7439-92-1
China RoHS	Environmentally Friendly Use Period = 25; For information on hazardous substances, refer to the manufacturer's declaration available under "Downloads"

QUINT-PS/1AC/24DC/ 5 - Power supply unit



2866750

<https://www.phoenixcontact.com/in/products/2866750>

Accessories

UTA 107/30 - Mounting adapter

2320089

<https://www.phoenixcontact.com/in/products/2320089>

Universal DIN rail adapter

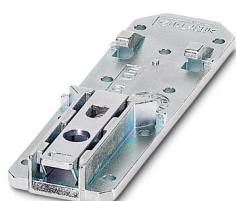

UWA 182/52 - Mounting adapter

2938235

<https://www.phoenixcontact.com/in/products/2938235>

Universal wall adapter for securely mounting the device in the event of strong vibrations. The device is screwed directly onto the mounting surface. The universal wall adapter is attached on the top/bottom.



QUINT-PS/1AC/24DC/ 5 - Power supply unit

2866750

<https://www.phoenixcontact.com/in/products/2866750>



QUINT-PS-ADAPTERS7/1 - Mounting adapter

2938196

<https://www.phoenixcontact.com/in/products/2938196>

Assembly adapter for QUINT-PS... power supply on S7-300 rail



QUINT-PS/FAN/4 - Fan

2320076

<https://www.phoenixcontact.com/in/products/2320076>



The fan for QUINT-PS/1AC and .../3AC can be mounted without the need for tools or other accessories. By using the fan, optimum cooling is ensured at high ambient temperatures or if the mounting position is rotated.

QUINT-PS/1AC/24DC/ 5 - Power supply unit

2866750

<https://www.phoenixcontact.com/in/products/2866750>



QUINT-DIODE/12-24DC/2X20/1X40 - Redundancy module

2320157

<https://www.phoenixcontact.com/in/products/2320157>



DIN rail diode module 12-24 V DC/2x20 A or 1x40 A. Uniform redundancy up to the consumer.

QUINT-ORING/24DC/2X10/1X20 - Redundancy module, with protective coating

2320173

<https://www.phoenixcontact.com/in/products/2320173>



Active QUINT redundancy module for DIN rail mounting with Auto Current Balancing ACB technology and monitoring functions, input: 24 V DC, output: 24 V DC/2 x 10 A or 1 x 20 A, including mounted UTA 107/30 universal DIN rail adapter

QUINT-PS/1AC/24DC/ 5 - Power supply unit

2866750

<https://www.phoenixcontact.com/in/products/2866750>



TRIO-DIODE/12-24DC/2X10/1X20 - Redundancy module

2866514

<https://www.phoenixcontact.com/in/products/2866514>



Redundancy module with function monitoring, 12 ... 24 V DC, 2x 10 A, 1x 20 A

CB TM1 1A SFB P - Thermomagnetic device circuit breaker

2800836

<https://www.phoenixcontact.com/in/products/2800836>



Thermomagnetic device circuit breaker, 1-pos., tripping characteristic SFB, 1 changeover contact, plug for base element.

QUINT-PS/1AC/24DC/ 5 - Power supply unit



2866750

<https://www.phoenixcontact.com/in/products/2866750>

CB TM1 2A SFB P - Thermomagnetic device circuit breaker

2800837

<https://www.phoenixcontact.com/in/products/2800837>



Thermomagnetic device circuit breaker, 1-pos., tripping characteristic SFB, 1 changeover contact, plug for base element.

PLT-SEC-T3-230-FM-UT - Type 3 surge protection device

2907919

<https://www.phoenixcontact.com/in/products/2907919>



Type 2/3 surge protection, consisting of protective plug and base element with screw connection. For single-phase power supply network with integrated status indicator and remote signaling. Nominal voltage: 230 V AC/DC

QUINT-PS/1AC/24DC/ 5 - Power supply unit

2866750

<https://www.phoenixcontact.com/in/products/2866750>



PLT-SEC-T3-24-FM-UT - Type 3 surge protection device

2907916

<https://www.phoenixcontact.com/in/products/2907916>



Type 3 surge protection, consisting of protective plug and base element, with integrated status indicator and remote signaling for single-phase power supply networks. Nominal voltage: 24 V AC/DC

Phoenix Contact 2023 © - all rights reserved

<https://www.phoenixcontact.com>

PHOENIX CONTACT (I) Pvt. Ltd.

A-58/2, Okhla Industrial Area, Phase - II, New Delhi-110 020

+91.1275.71420

info@phoenixcontact.co.in