

HC-STA-B32-BWD-ELC-AL - Housing



1424845

<https://www.phoenixcontact.com/in/products/1424845>

Please be informed that the data shown in this PDF document is generated from our online catalog. Please find the complete data in the user documentation. Our general terms of use for downloads are valid.



Panel mounting base B32, with double locking latch, material: Die-cast aluminum, salt water resistant, height: 32.4 mm, cable gland: none, Standard, with flat gasket

Your advantages

- Good shielding in the event of electromagnetic interference

Commercial data

Item number	1424845
Packing unit	1 pc
Minimum order quantity	1 pc
Sales key	BF7
Product key	BF7APB
Catalog page	Page 644 (C-2-2019)
GTIN	4055626382500
Weight per piece (including packing)	186.4 g
Weight per piece (excluding packing)	180 g
Customs tariff number	85389099
Country of origin	CN

HC-STA-B32-BWD-ELC-AL - Housing

1424845

<https://www.phoenixcontact.com/in/products/1424845>

Technical data

Product properties

Product type	Housing with locking latch
Housing type	Panel mounting base
Application	Standard
Type	B32
Pg screw connection	none

Data management status

Article revision	01
------------------	----

Dimensions

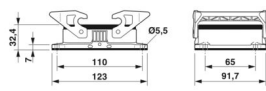
Dimensional drawing	
Width	91.7 mm
Height	32.4 mm
Length	123 mm
Drill hole distance, horizontal	110 mm
Drill hole distance, vertical	65 mm
Hole diameter	5.5 mm

Installation dimensions

Width of the assembly cutout	71 mm
Length of the assembly cutout	86 mm

Material specifications

Flammability rating according to UL 94	V0 (Interlock)
Seal material	NBR, conductive NBR, conductive
Housing material	Die-cast aluminum, salt water resistant
Housing surface material	uncoated
Locking latch material	PA

Mechanical properties

Mechanical data

Locking type	Latch
--------------	-------

Connection data

Tightening torque	2 Nm ... 3 Nm (For M5 mounting screws on the panel-mount base)
-------------------	--

Environmental and real-life conditions

HC-STA-B32-BWD-ELC-AL - Housing



1424845

<https://www.phoenixcontact.com/in/products/1424845>

Ambient conditions

Degree of protection	IP66
	IP67
Enclosure rating (NEMA)	4 (UL 50e)
	4X (UL 50e)
	12 (UL 50e)
Impact strength	IK09
Ambient temperature (operation)	-40 °C ... 125 °C

HC-STA-B32-BWD-ELC-AL - Housing

1424845

<https://www.phoenixcontact.com/in/products/1424845>

Drawings

Dimensional drawing

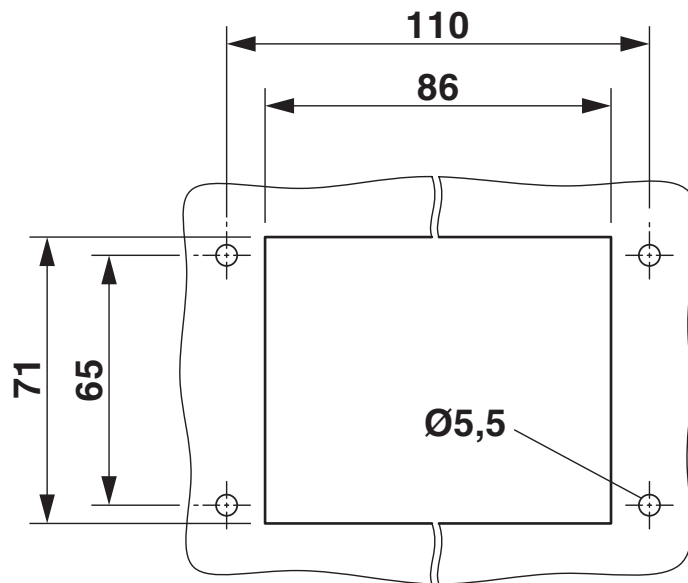

Mounting cutout

Dimensional drawing

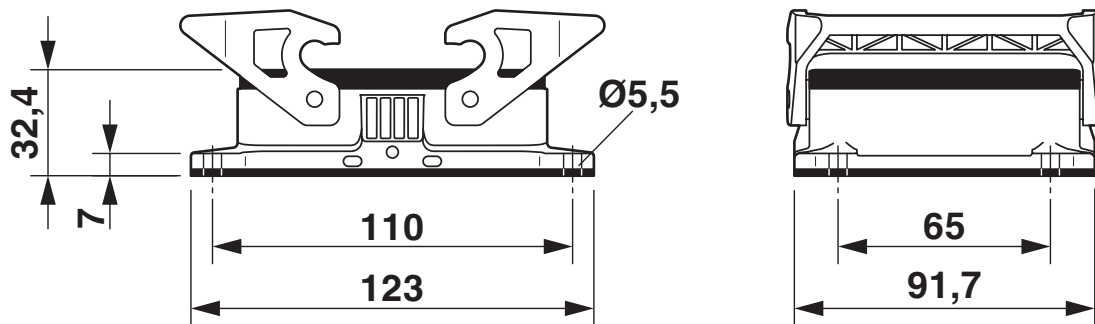

Dimensional drawing

1424845

<https://www.phoenixcontact.com/in/products/1424845>

Approvals

🔗 To download certificates, visit the product detail page: <https://www.phoenixcontact.com/in/products/1424845>

DNV

Approval ID: TAE000037S



cUL Recognized

Approval ID: E255026



UL Recognized

Approval ID: E255026



EAC

Approval ID: RU C-DE.BL08.B.00511

cULus Recognized

HC-STA-B32-BWD-ELC-AL - Housing



1424845

<https://www.phoenixcontact.com/in/products/1424845>

Classifications

ECLASS

ECLASS-11.0	27440202
ECLASS-12.0	27440202
ECLASS-13.0	27440202

ETIM

ETIM 9.0	EC000437
----------	----------

UNSPSC

UNSPSC 21.0	31261500
-------------	----------

HC-STA-B32-BWD-ELC-AL - Housing



1424845

<https://www.phoenixcontact.com/in/products/1424845>

Environmental product compliance

EU RoHS

Fulfills EU RoHS substance requirements	Yes, No exemptions
---	--------------------

China RoHS

Environment friendly use period (EFUP)	EFUP-E
	No hazardous substances above the limits

EU REACH SVHC

REACH candidate substance (CAS No.)	No substance above 0.1 wt%
-------------------------------------	----------------------------

HC-STA-B32-BWD-ELC-AL - Housing



1424845

<https://www.phoenixcontact.com/in/products/1424845>

Accessories

HC-STA-B32-BCSFD-PL-BK - Protective cover

1424850

<https://www.phoenixcontact.com/in/products/1424850>

Protective cover B32, for double locking latch, protective cover material: PA, height: 24.8 mm, seal: no, Standard, with lanyard



US-EMLP-HA (20X9) - Plastic label

0830989

<https://www.phoenixcontact.com/in/products/0830989>

Plastic label, Card, white, unlabeled, can be labeled with: BLUEMARK ID COLOR, BLUEMARK ID, THERMOMARK PRIME, THERMOMARK CARD 2.0, THERMOMARK CARD, mounting type: adhesive, lettering field size: 20 x 9 mm, Number of individual labels: 70



HC-STA-B32-BWD-ELC-AL - Housing

1424845

<https://www.phoenixcontact.com/in/products/1424845>



US-EMLP-HA (20X9) CUS - Plastic label

0830995

<https://www.phoenixcontact.com/in/products/0830995>

Plastic label, Card, can be ordered: by card, white, labeled, can be labeled with: THERMOMARK CARD, mounting type: adhesive, lettering field size: 20 x 9 mm, Number of individual labels: 70



Phoenix Contact 2024 © - all rights reserved

<https://www.phoenixcontact.com>

PHOENIX CONTACT (I) Pvt. Ltd.

A-58/2, Okhla Industrial Area, Phase - II, New Delhi-110 020

+91.1275.71420

info@phoenixcontact.co.in