

Built-in Amplifier Photoelectric Sensor (Medium Size)

E3S-AT21 5M



Image

Medium Photoelectric Sensor With Built-in Amplifier, Through-beam type, Horizontal, Sensing distance: 7 m, NPN, Timer/Self diagnosis function, External Diagnosis function, Turbo function, Pre-wired model, 5 m

Sensing method	Through-beam type
Sensing distance	7 m
Light source	Red LED (660 nm)
Connection method	Pre-wired models

Ratings/Performance

As of July 25, 2024

Shape	Square type
Sensing method	Through-beam type
Sensing distance	7 m
Standard sensing object	Opaque: 10 mm dia. min.
Directional angle	Emitter: 3 to 15 ° Receiver: 3 to 15 °
Light source	Red LED (660 nm)
Power supply voltage	10 to 30 VDC ripple (p-p) 10% included
Current consumption	Emitter: 20 mA max. Receiver: 20 mA max. Note: (plus approx. 15 mA with turbo function)
Control output	NPN open collector 30 VDC max. 100 mA max. Residual voltage: 1 V max.
Operation mode	Light-ON/Dark-ON selectable
Protective circuit	Output short-circuit protection, Power supply reverse polarity protection
Response time	Operate or reset: 0.5 ms max.
Sensitivity setting	2-turn endless adjustment (with indicator)
Self-diagnostic output	50 mA max., 30 VDC (residual voltage: 1 V max.), open collector
Timer function	OFF-delay 0 to 100 ms
Ambient illuminance	Incandescent lamp: 5,000 lx max. Sunlight: 10,000 lx max.
Ambient temperature range (Operating)	-25 to 55 °C (with no freezing or condensation)

Ambient temperature range (Storage)	-40 to 70 °C (with no freezing or condensation)
Ambient humidity range (Operating)	35 to 85 % (with no condensation)
Ambient humidity range (Storage)	35 to 95 % (with no condensation)
Insulation resistance	20 MΩ min. (500 VDC megger)
Dielectric strength	1000 VAC 50/60 Hz 1 min
Vibration resistance	Destruction: 10 to 55 Hz, 1.5 mm double amplitude each in X, Y, and Z directions for 2 h
Shock resistance	Destruction: 500 m/s ² 3 times each in X, Y and Z directions
Degree of protection	IEC: IP67 NEMA 4X (indoors only)
Connection method	Pre-wired models (Cable length 5 m)
Indicator	Light indicator (red), Stability indicator (green), Power indicator (red)
Accessories	Instruction manual, Mounting bracket, Sensitivity adjustment driver, Sensitivity adjusting knob
Material	Case: Polybutylene terephthalate (PBT) Lens: Denatured Polyarylate Mounting Bracket: Stainless steel (SUS304)

As of July 25, 2024

Dimensions

As of July 25, 2024

E3S-AT11/21/31/41 (Receiver)

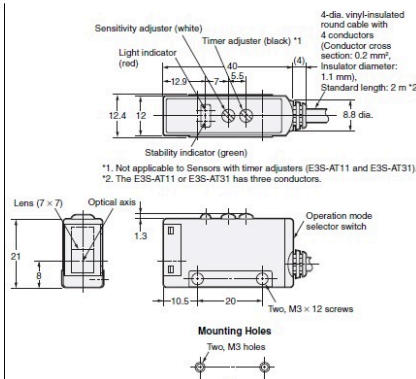
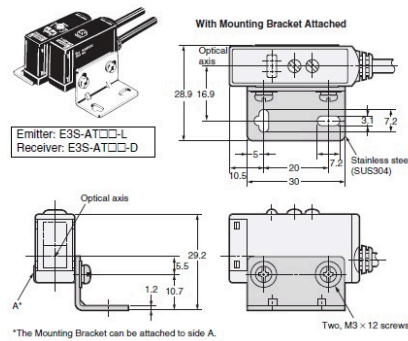

E3S-AT21/41 (Emitter)

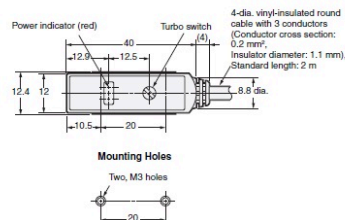
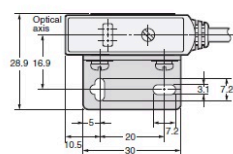

As of July 25, 2024

Output circuit diagram

As of July 25, 2024

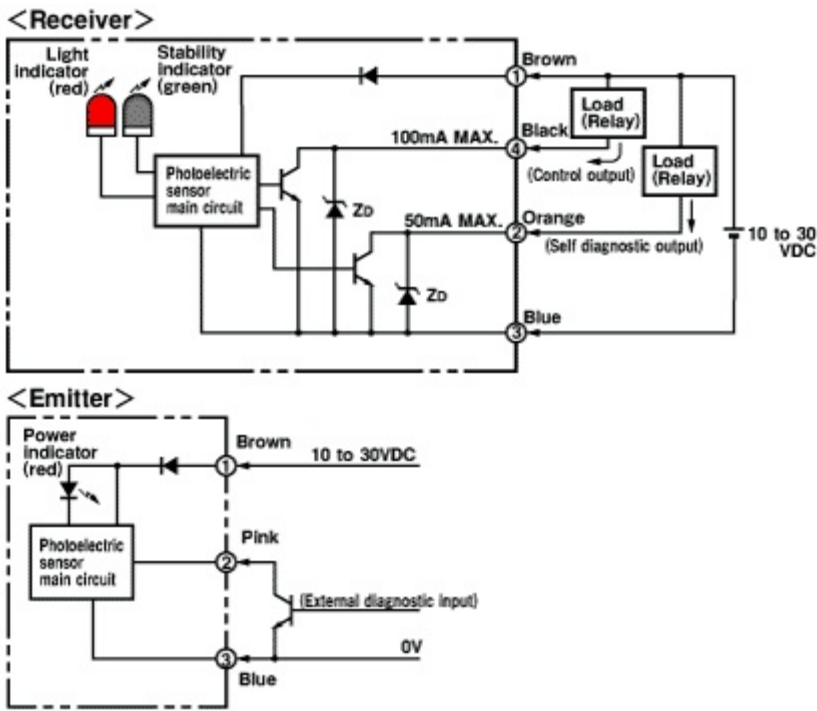

As of July 25, 2024

Timing chart

As of July 25, 2024

Operation mode	Timing chart	Mode switch
Light ON	<p>Incident light</p> <p>No incident light</p> <p>Light indicator (red) ON</p> <p>Light indicator (red) OFF</p> <p>Output transistor ON</p> <p>Output transistor OFF</p> <p>Load (Relay) Operate</p> <p>Load (Relay) Reset</p> <p>{Between brown(1) and black(4)}</p> <p>T : OFF delay timer (0~100ms)</p>	L side (LIGHT ON)
Dark ON	<p>Incident light</p> <p>No incident light</p> <p>Light Indicator (red) ON</p> <p>Light Indicator (red) OFF</p> <p>Output transistor ON</p> <p>Output transistor OFF</p> <p>Load (Relay) Operate</p> <p>Load (Relay) Reset</p> <p>{Between brown(1) and black(4)}</p> <p>T : OFF delay timer (0~100ms)</p>	D side (DARK ON)
—	<p>External diagnostic Input ON</p> <p>External diagnostic Input OFF</p> <p>{Between blue(3) and pink(2)}</p> <p>Emitter LED ON</p> <p>Emitter LED OFF</p> <p>Indicator(red) ON</p> <p>Indicator(red) OFF</p>	—

As of July 25, 2024

Parallel operating range

As of July 25, 2024

Through-beam Sensors
E3S-AT□□

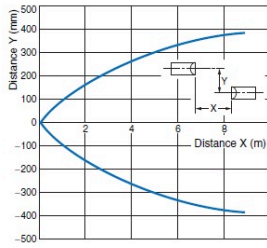

Through-beam Sensors
E3S-AT□□ + E39-S46
(Slit Sold Separately)

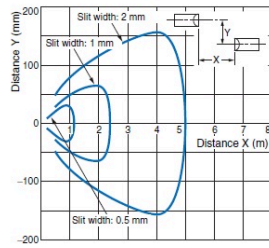

Through-beam Sensors
E3S-AT□□ + E39-E6
(Filter Sold Separately)

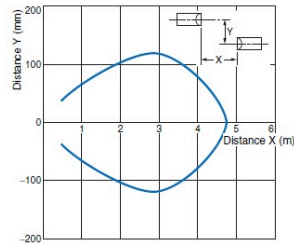

As of July 25, 2024

Setting distance

As of July 25, 2024

Excess gain ratio vs. setting distance

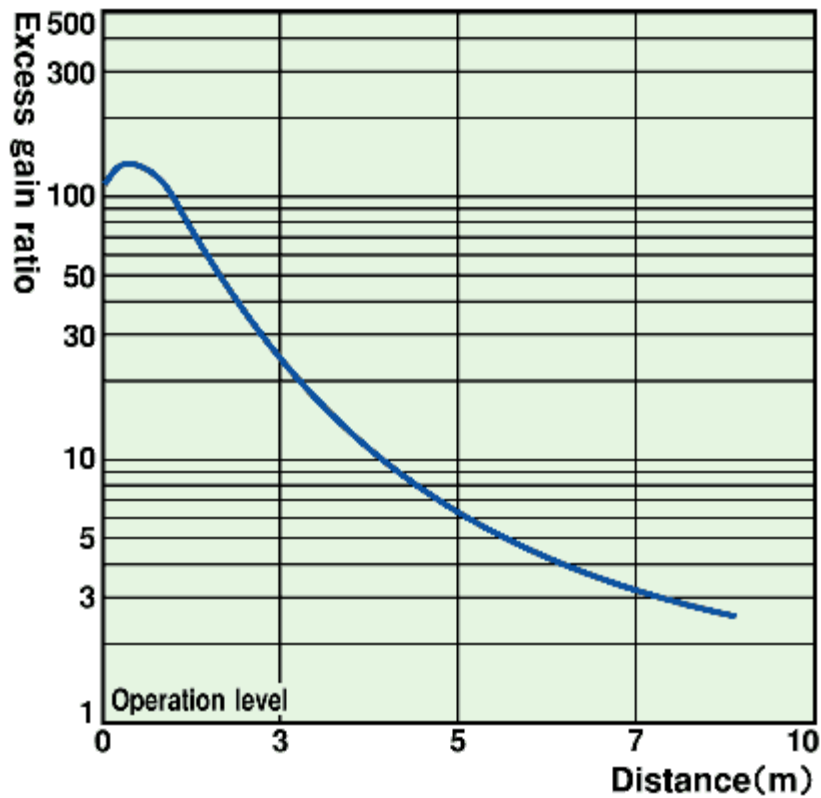

As of July 25, 2024