

Built-in Amplifier Photoelectric Sensor (Medium Size)

E3S-AT21 2M



Image

Medium Photoelectric Sensor With Built-in Amplifier, Through-beam type, Horizontal, Sensing distance: 7 m, NPN, Timer/Self diagnosis function, External Diagnosis function, Turbo function, Pre-wired model, 2 m

Sensing method	Through-beam type
Sensing distance	7 m
Light source	Red LED (660 nm)
Connection method	Pre-wired models

Ratings/Performance

As of July 25, 2024

Shape	Square type
Sensing method	Through-beam type
Sensing distance	7 m
Standard sensing object	Opaque: 10 mm dia. min.
Directional angle	Emitter: 3 to 15 ° Receiver: 3 to 15 °
Light source	Red LED (660 nm)
Power supply voltage	10 to 30 VDC ripple (p-p) 10% included
Current consumption	Emitter: 20 mA max. Receiver: 20 mA max. Note: (plus approx. 15 mA with turbo function)
Control output	NPN open collector 30 VDC max. 100 mA max. Residual voltage: 1 V max.
Operation mode	Light-ON/Dark-ON selectable
Protective circuit	Output short-circuit protection, Power supply reverse polarity protection
Response time	Operate or reset: 0.5 ms max.
Sensitivity setting	2-turn endless adjustment (with indicator)
Self-diagnostic output	50 mA max., 30 VDC (residual voltage: 1 V max.), open collector
Timer function	OFF-delay 0 to 100 ms
Ambient illuminance	Incandescent lamp: 5,000 lx max. Sunlight: 10,000 lx max.
Ambient temperature range (Operating)	-25 to 55 °C (with no freezing or condensation)

Ambient temperature range (Storage)	-40 to 70 °C (with no freezing or condensation)
Ambient humidity range (Operating)	35 to 85 % (with no condensation)
Ambient humidity range (Storage)	35 to 95 % (with no condensation)
Insulation resistance	20 MΩ min. (500 VDC megger)
Dielectric strength	1000 VAC 50/60 Hz 1 min
Vibration resistance	Destruction: 10 to 55 Hz, 1.5 mm double amplitude each in X, Y, and Z directions for 2 h
Shock resistance	Destruction: 500 m/s ² 3 times each in X, Y and Z directions
Degree of protection	IEC: IP67 NEMA 4X (indoors only)
Connection method	Pre-wired models (Cable length 2 m)
Indicator	Light indicator (red), Stability indicator (green), Power indicator (red)
Weight	Package: Approx. 150 g
Accessories	Instruction manual, Mounting bracket, Sensitivity adjustment driver, Sensitivity adjusting knob
Material	Case: Polybutylene terephthalate (PBT) Lens: Denatured Polyarylate Mounting Bracket: Stainless steel (SUS304)

As of July 25, 2024

Dimensions

As of July 25, 2024

E3S-AT11/21/31/41 (Receiver)

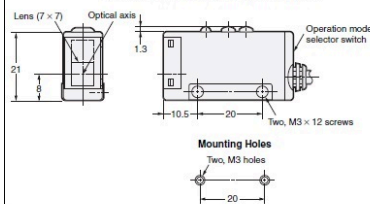
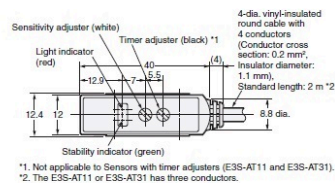
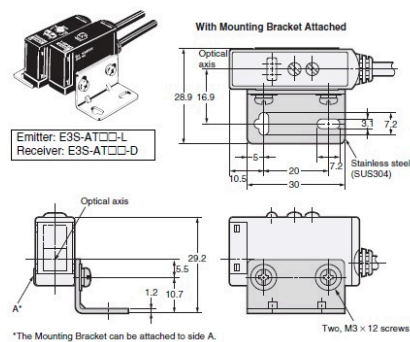

E3S-AT21/41 (Emitter)

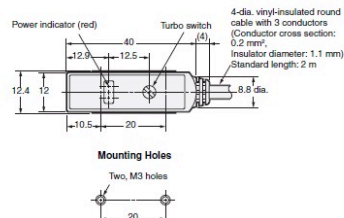
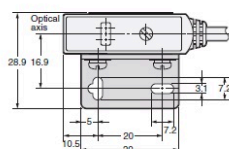

As of July 25, 2024

Output circuit diagram

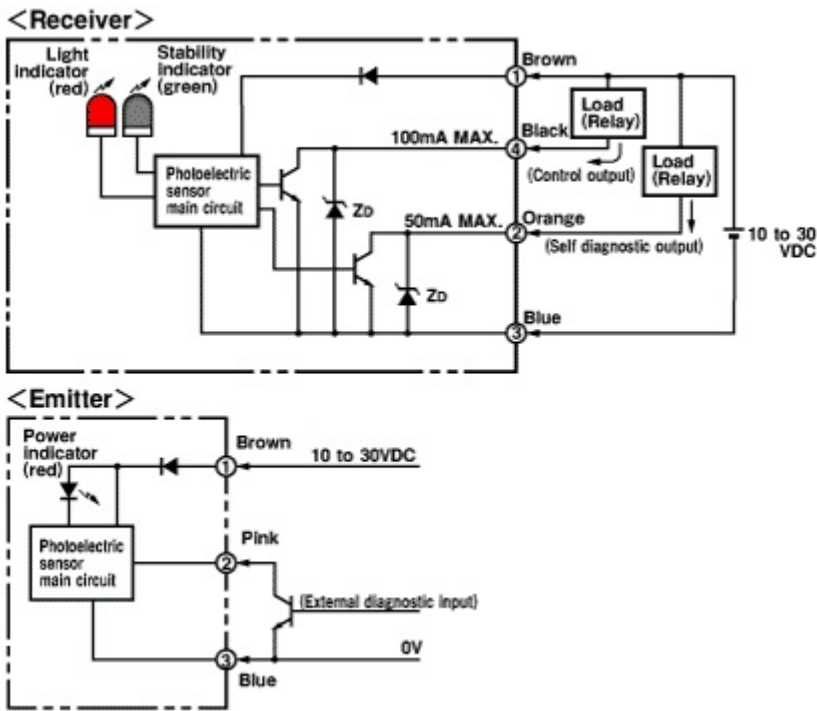

Timing chart

Operation mode	Timing chart	Mode switch
Light ON	<p>Incident light: ON (green bar), OFF (no bar)</p> <p>No incident light: OFF (no bar)</p> <p>Light Indicator (red): ON (red bar), OFF (no bar)</p> <p>Output transistor: ON (green bar), OFF (no bar)</p> <p>Load (Relay): Operate (green bar), Reset (no bar)</p> <p>{Between brown(1) and black(4)}</p> <p>T : OFF delay timer (0~100ms)</p>	L side (LIGHT ON)
Dark ON	<p>Incident light: ON (green bar), OFF (no bar)</p> <p>No incident light: ON (green bar), OFF (no bar)</p> <p>Light Indicator (red): ON (red bar), OFF (no bar)</p> <p>Output transistor: ON (green bar), OFF (no bar)</p> <p>Load (Relay): Operate (green bar), Reset (no bar)</p> <p>{Between brown(1) and black(4)}</p> <p>T : OFF delay timer (0~100ms)</p>	D side (DARK ON)
—	<p>External diagnostic Input: ON (green bar), OFF (no bar)</p> <p>{Between blue(3) and pink(2)}</p> <p>Emitter LED: ON (green bar), OFF (no bar)</p> <p>Indicator(red): ON (red bar), OFF (no bar)</p>	—

Parallel operating range

As of July 25, 2024

Through-beam Sensors
E3S-AT□□

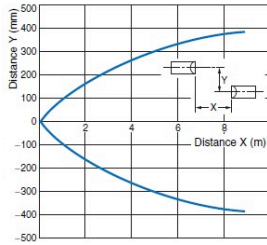

Through-beam Sensors
E3S-AT□□ + E39-S46
(Slit Sold Separately)

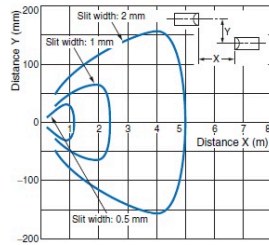

Through-beam Sensors
E3S-AT□□ + E39-E6
(Filter Sold Separately)

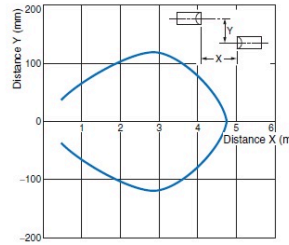

As of July 25, 2024

Setting distance

As of July 25, 2024

Excess gain ratio vs. setting distance

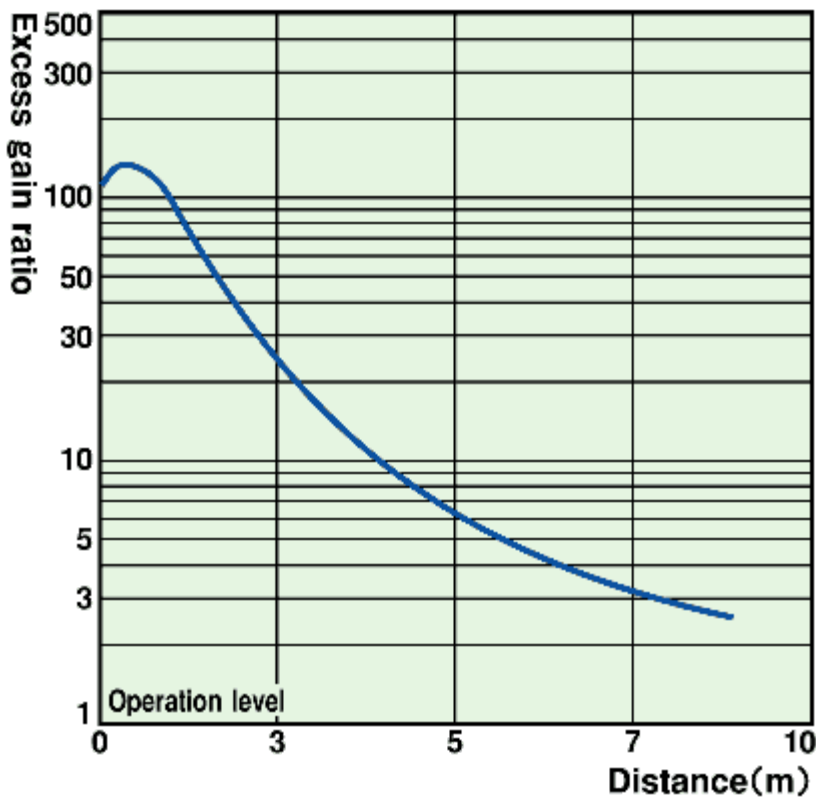

As of July 25, 2024