



AZ 17-11ZRI B6L

- cable gland M16
- left-hand model
- For very small actuating radii in line with or at 90° to the plane of the actuator
- Thermoplastic enclosure
- Double-insulated
- Long life
- 30 mm x 60 mm x 30 mm
- small body
- Individual coding
- Coding level "High" according to ISO 14119
- High level of contact reliability with low voltages and currents
- Insensitive to soiling
- Slot sealing plug included
- 8 actuating planes

Data

Ordering data

Product type description	AZ 17-11ZRI B6L
Article number (order number)	101136307
EAN (European Article Number)	4030661280424
eCl@ss number, version 12.0	27-27-26-02
eCl@ss number, version 11.0	27-27-26-02
eCl@ss number, version 9.0	27-27-26-02
ETIM number, version 7.0	EC002592
ETIM number, version 6.0	EC002592

General data

Standards	EN ISO 13849-1 EN ISO 14119 EN IEC 60947-5-1
Coding level according to EN ISO 14119	High
Working principle	electromechanical
Housing material	Plastic, glass-fibre reinforced thermoplastic, self-extinguishing
Material of the actuator	Stainless steel
Gross weight	100 g

General data - Features

Increased latching force	Yes
Number of actuating directions	2
Number of auxiliary contacts	1
Number of safety contacts	1
Number of cable glands	1

Safety classification

Standards	EN IEC 60947-5-1
Performance Level, up to	c
Category	1
B _{10D} Normally-closed contact (NC)	2,000,000 Operations
Note	Electrical life on request.
B _{10D} Normally-open contact (NO)	1,000,000 Operations
Note	at 10% I _e and ohmic load
Mission time	20 Year(s)

Safety classification - Fault exclusion

Please note:	Can be used when fault exclusion for dangerous damage to the 1-channel mechanism is permissible and sufficient protection against manipulation is guaranteed.
Performance Level, up to	d

Category	3
Note	for 2-channel use and with suitable logic unit.
Mission time	20 Year(s)

Mechanical data

Mechanical life, minimum	1,000,000 Operations
Latching force	30 N
Positive break travel	11 mm
Positive break force per NC contact, minimum	17 N
Actuating speed, maximum	2 m/s
Mounting	Screws
Type of the fixing screws	2x M5
Tightening torque of the fastening screws for the housing cover, minimum	0.7 Nm
Tightening torque of the fastening screws for the housing cover, maximum	1 Nm
Note	Torx T10

Mechanical data - Connection technique

Cable entry	M 16 x 1.5
Termination	IDC method of termination
Cable section, minimum	0.75 mm ²
Cable section, maximum	1 mm ²
Note (Cable section)	All indications including the conductor ferrules.
Allowed type of cable	flexible

Mechanical data - Dimensions

Length of sensor	30 mm
Width of sensor	30 mm

Height of sensor	85 mm
------------------	-------

Ambient conditions

Degree of protection	IP67
Ambient temperature	-30 ... +80 °C
Storage and transport temperature, minimum	-30 °C
Storage and transport temperature, maximum	+85 °C
Permissible installation altitude above sea level, maximum	2,000 m

Ambient conditions - Insulation values

Rated insulation voltage U_i	250 VAC
Rated impulse withstand voltage U_{imp}	4 kV
Overvoltage category	III
Degree of pollution	3

Electrical data

Thermal test current	10 A
Required rated short-circuit current	1,000 A
Switching element	NO contact, NC contact
Switching principle	slow action, positive break NC contact
Switching frequency	2,000 /h
Material of the contacts, electrical	Silver

Electrical data - Safety contacts

Voltage, Utilisation category AC-15	230 VAC
Current, Utilisation category AC-15	4 A
Voltage, Utilisation category DC-13	24 VDC

Current, Utilisation category DC-13 4 A

Electrical data - Auxiliary contacts

Voltage, Utilisation category AC-15 230 VAC

Current, Utilisation category AC-15 4 A

Voltage, Utilisation category DC-13 24 VDC

Current, Utilisation category DC-13 4 A

Scope of delivery

Scope of delivery Not available as spare part
Slot cover for dust-proof covering of the opening not in use

Note

Note (General) This type termination (IDC) method enables simple connection of flexible conductors without the need for the use of conductor ferrules
The actuator is not available separately.

Ordering code

Product type description:
AZ 17-(1)Z(2)I-(3)-(4)-(5)

(1)

11 1 NO contacts/1 NC contact

02 2 NC contact

(2)

without Latching force 5 N

R Latching force 30 N

(3)

without M16 cable gland

ST M12 connector

(4)

B1	Actuator B1
B5	Actuator B5
B6L	Actuator B6L
B6R	Actuator B6R

(5)

1637	Gold-plated contacts
-------------	----------------------

Pictures

Product picture (catalogue individual photo)



ID: kaz17f15

| 1.5 MB | .jpg | 352.778 x 1102.783 mm - 1000 x 3126 px - 72 dpi

| 120.0 kB | .png | 74.083 x 231.422 mm - 210 x 656 px - 72 dpi

| 23.9 kB | .jpg | 39.511 x 123.472 mm - 112 x 350 px - 72 dpi

Dimensional drawing basic component

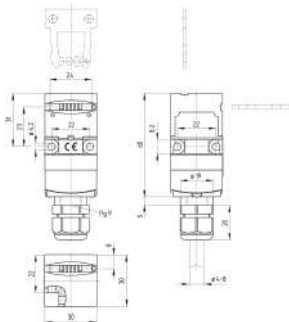

ID: kaz17gi1

| 47.7 kB | .cdr |

| 5.8 kB | .png | 74.083 x 83.256 mm - 210 x 236 px - 72 dpi

| 170.0 kB | .jpg | 352.778 x 396.522 mm - 1000 x 1124 px - 72 dpi

Dimensional drawing actuator

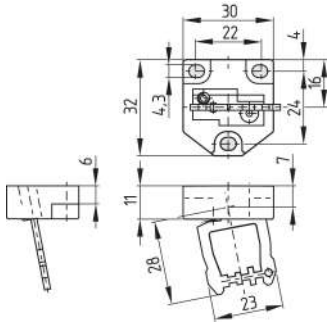

ID: 1azm1b07

| 155.3 kB | .jpg | 352.778 x 352.778 mm - 1000 x 1000 px - 72 dpi

| 19.5 kB | .png | 74.083 x 74.083 mm - 210 x 210 px - 72 dpi

Switch travel diagram

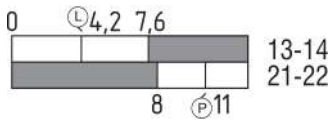

ID: kaz17s01

| 19.6 kB | .cdr |

| 2.0 kB | .png | 74.083 x 26.458 mm - 210 x 75 px - 72 dpi

| 52.6 kB | .jpg | 352.778 x 125.236 mm - 1000 x 355 px - 72 dpi

Diagram

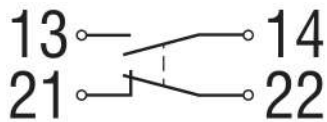

ID: k1o1sk01

| 52.2 kB | .jpg | 352.778 x 143.581 mm - 1000 x 407 px - 72 dpi

| 2.6 kB | .png | 74.083 x 29.986 mm - 210 x 85 px - 72 dpi

Assembly example



ID: kaz17m02

| 210.2 kB | .cdr |

Actuating radius

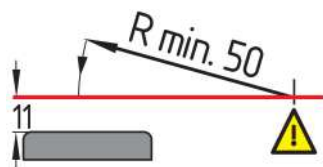

ID: kaz17r01

| 19.8 kB | .cdr |

| 3.2 kB | .png | 74.083 x 38.1 mm - 210 x 108 px - 72 dpi

| 71.2 kB | .jpg | 352.778 x 180.622 mm - 1000 x 512 px - 72 dpi

Actuating radius

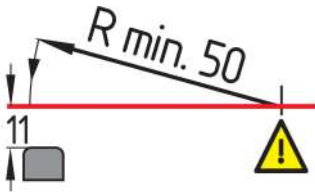

ID: kaz17r02
| 19.8 kB | .cdr |
| 3.5 kB | .png | 74.083 x 44.45 mm - 210 x 126 px - 72 dpi
| 84.0 kB | .jpg | 352.778 x 211.667 mm - 1000 x 600 px - 72 dpi

Schmersal India Pvt. Ltd., Plot No - G-7/1, Ranjangaon MIDC, Tal. - Shirur, Dist.- Pune 412 220

The details and data referred to have been carefully checked. Images may diverge from original. Further technical data can be found in the manual. Technical amendments and errors possible.

Generated on: 08/12/2023, 10:26 am