



AZ 17-11ZI-ST B6L

- Connector M12 x 1, 4-pole
- left-hand model
- For very small actuating radii in line with or at 90° to the plane of the actuator
- Thermoplastic enclosure
- Double-insulated
- Long life
- 30 mm x 60 mm x 30 mm
- small body
- Individual coding
- Coding level "High" according to ISO 14119
- High level of contact reliability with low voltages and currents
- Insensitive to soiling
- Slot sealing plug included
- 8 actuating planes

Data

Ordering data

Product type description	AZ 17-11ZI-ST B6L
Article number (order number)	101144085
EAN (European Article Number)	4030661130842
eCl@ss number, version 12.0	27-27-26-02
eCl@ss number, version 11.0	27-27-26-02
eCl@ss number, version 9.0	27-27-26-02
ETIM number, version 7.0	EC002592
ETIM number, version 6.0	EC002592

Approvals - Standards

Certificates	BG cULus
--------------	-------------

General data

Standards	EN ISO 13849-1 EN ISO 14119 EN IEC 60947-5-1
Coding level according to EN ISO 14119	High
Working principle	electromechanical
Housing material	Plastic, glass-fibre reinforced thermoplastic, self-extinguishing
Material of the actuator	Stainless steel
Gross weight	91 g

General data - Features

Number of actuating directions	2
Number of auxiliary contacts	1
Number of safety contacts	1
Number of cable glands	1

Safety classification

Standards	EN ISO 13849-1 EN IEC 60947-5-1
Performance Level, up to	c
Category	1
B _{10D} Normally-closed contact (NC)	2,000,000 Operations
Note	Electrical life on request.
B _{10D} Normally-open contact (NO)	1,000,000 Operations
Note	at 10% I _e and ohmic load
Mission time	20 Year(s)

Safety classification - Fault exclusion

Please note:	Can be used when fault exclusion for dangerous damage to the 1-channel mechanism is permissible and sufficient protection against manipulation is guaranteed.
Performance Level, up to	d
Category	3
Note	for 2-channel use and with suitable logic unit.
Mission time	20 Year(s)

Mechanical data

Mechanical life, minimum	1,000,000 Operations
Latching force	5 N
Positive break travel	11 mm
Positive break force per NC contact, minimum	17 N
Actuating speed, maximum	2 m/s
Mounting	Screws
Type of the fixing screws	2x M5

Mechanical data - Connection technique

Termination	Connector plug M12, 4-pole, (A-coding)
-------------	--

Mechanical data - Dimensions

Length of sensor	30 mm
Width of sensor	30 mm
Height of sensor	85 mm

Ambient conditions

Degree of protection	IP67
Ambient temperature	-30 ... +80 °C

Storage and transport temperature, minimum	-30 °C
Storage and transport temperature, maximum	+85 °C
Permissible installation altitude above sea level, maximum	2,000 m

Ambient conditions - Insulation values

Rated insulation voltage U_i	250 VAC
Rated impulse withstand voltage U_{imp}	4 kV
Overtoltage category	III
Degree of pollution	3

Electrical data

Thermal test current	10 A
Required rated short-circuit current	1,000 A
Switching element	NO contact, NC contact
Switching principle	slow action, positive break NC contact
Switching frequency	2,000 /h
Material of the contacts, electrical	Silver

Electrical data - Safety contacts

Voltage, Utilisation category AC-15	230 VAC
Current, Utilisation category AC-15	4 A
Voltage, Utilisation category DC-13	24 VDC
Current, Utilisation category DC-13	4 A

Electrical data - Auxiliary contacts

Voltage, Utilisation category AC- 230 VAC
15

Current, Utilisation category AC- 4 A
15

Voltage, Utilisation category DC- 24 VDC
13

Current, Utilisation category DC- 4 A
13

Scope of delivery

Scope of delivery Not available as spare part
Slot cover for dust-proof covering of the opening not in use

Note

Note (General) The axis of the hinge must be 11 mm above and in a parallel plane to the top surface of the safety switch.
Actuating radius adjustable, minimum 50 mm, using an hexagonal key wrench SW 2 mm (a and b)
The actuator is not available separately.

Ordering code

Product type description:
AZ 17-(1)Z(2)I-(3)-(4)-(5)

(1)	
11	1 NO contacts/1 NC contact
02	2 NC contact
(2)	
without	Latching force 5 N
R	Latching force 30 N
(3)	
without	M16 cable gland

ST M12 connector

(4)

B1 Actuator B1

B5 Actuator B5

B6L Actuator B6L

B6R Actuator B6R

(5)

1637 Gold-plated contacts

Pictures

Product picture (catalogue individual photo)



ID: kaz17fi2

| 281.9 kB | .jpg | 122.061 x 359.481 mm - 346 x 1019 px - 72 dpi

| 148.6 kB | .png | 74.083 x 218.017 mm - 210 x 618 px - 72 dpi

| 29.3 kB | .jpg | 41.981 x 123.472 mm - 119 x 350 px - 72 dpi

Dimensional drawing basic component

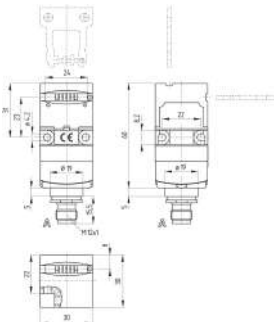

ID: kaz17gi2

| 111.5 kB | .cdr |

| 5.8 kB | .png | 74.083 x 86.783 mm - 210 x 246 px - 72 dpi

| 168.7 kB | .jpg | 352.425 x 413.456 mm - 999 x 1172 px - 72 dpi

Dimensional drawing actuator

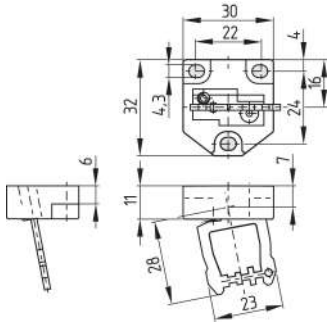

ID: 1azm1b07

| 155.3 kB | .jpg | 352.778 x 352.778 mm - 1000 x 1000 px - 72 dpi

| 19.5 kB | .png | 74.083 x 74.083 mm - 210 x 210 px - 72 dpi

Switch travel diagram

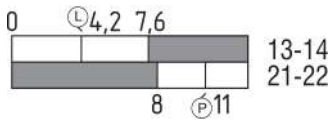

ID: kaz17s01

| 19.6 kB | .cdr |

| 2.0 kB | .png | 74.083 x 26.458 mm - 210 x 75 px - 72 dpi

| 52.6 kB | .jpg | 352.778 x 125.236 mm - 1000 x 355 px - 72 dpi

Diagram

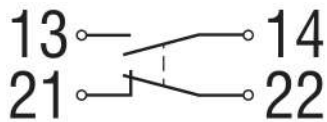

ID: k1o1sk01

| 52.2 kB | .jpg | 352.778 x 143.581 mm - 1000 x 407 px - 72 dpi

| 2.6 kB | .png | 74.083 x 29.986 mm - 210 x 85 px - 72 dpi

Actuating radius

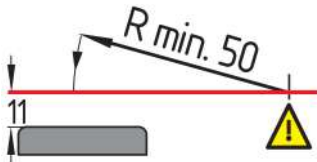

ID: kaz17r01

| 19.8 kB | .cdr |

| 3.2 kB | .png | 74.083 x 38.1 mm - 210 x 108 px - 72 dpi

| 71.2 kB | .jpg | 352.778 x 180.622 mm - 1000 x 512 px - 72 dpi

Actuating radius

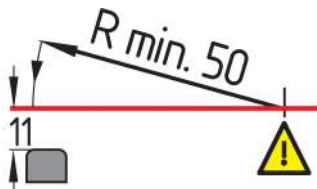

ID: kaz17r02

| 19.8 kB | .cdr |

| 3.5 kB | .png | 74.083 x 44.45 mm - 210 x 126 px - 72 dpi

| 84.0 kB | .jpg | 352.778 x 211.667 mm - 1000 x 600 px - 72 dpi

Contact arrangement

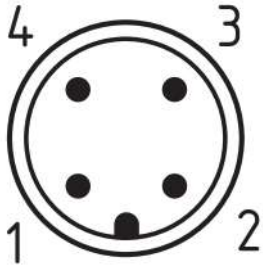

ID: km12-k4c

| 4.2 kB | .png | 74.083 x 74.083 mm - 210 x 210 px - 72 dpi

| 113.3 kB | .jpg | 352.778 x 352.778 mm - 1000 x 1000 px - 72 dpi

Schmersal India Pvt. Ltd., Plot No - G-7/1, Ranjangaon MIDC, Tal. - Shirur, Dist.- Pune 412 220

The details and data referred to have been carefully checked. Images may diverge from original. Further technical data can be found in the manual. Technical amendments and errors possible.

Generated on: 08/12/2023, 10:25 am