

FL WLAN 1101 - Wireless module



2702538

<https://www.phoenixcontact.com/in/products/2702538>

Please be informed that the data shown in this PDF document is generated from our Online Catalog. Please find the complete data in the user documentation. Our General Terms of Use for Downloads are valid.



WLAN access point, client for USA and Canada, with two internal antennas for single-hole mounting, IP54, WLAN 802.11 a, b, g, n, frequency: 2.4 GHz, 5 GHz, connections: COMBICON 9 ... 32 V DC, RJ45: for LAN, web, http/https, Command Line Interface

Commercial Data

Item number	2702538
Packing unit	1 pc
Minimum order quantity	1 pc
Sales Key	DNN
Product Key	DNN2W4
Catalog Page	Page 373 (C-6-2019)
GTIN	4055626279398
Weight per Piece (including packing)	375 g
Weight per Piece (excluding packing)	366 g
Customs tariff number	85176200
Country of origin	DE

Technical Data

Notes

Trade restriction

CE note	The products are offered exclusively for export outside the EU and the European Economic Area.
---------	--

Product properties

Type	Stand-Alone
Product type	Wireless module

Insulation characteristics

Overvoltage category	none
Pollution degree	2

Wireless card

Number	1
Type	IEEE 802.11 a/b/g/n 2.4 GHz and 5 GHz to 300 Mbps
Assembly instructions	Permanently installed

Electrical properties

Supply: Module electronics

Connection technology	COMBICON
Connection method	Push-in spring connection
Note on the connection method	Recommended conductor cross section: 0.75 mm ²
	Recommended ferrule: connection length 10 mm
	Recommended crimping pliers: trapezoidal or square
Designation	1966101 FMC 1,5/ 3-STF-3,5
Number of positions	3
Cross section range AWG	24 ... 16 (Use copper wires rated 75° C (UL))
Supply voltage	24 V DC (SELV)
Supply voltage range	18 V DC ... 32 V DC (PELV/SELV)
	9 V DC ... 32 V DC (PELV/SELV (from HW version 05))
Supply current	typ. 120 mA (at 24 V DC)
Current consumption	max. 250 mA (at 18 V DC)
	max. 400 mA (at 9 V DC)

Connection data

1966101 FMC 1,5/ 3-STF-3,5

Connection method	Push-in spring connection
Conductor cross section, rigid	0.2 mm ² ... 1.5 mm ²
Conductor cross section, flexible	0.2 mm ² ... 1.5 mm ²
Conductor cross section AWG	24 ... 16

FL WLAN 1101 - Wireless module



2702538

<https://www.phoenixcontact.com/in/products/2702538>

Stripping length	10 mm
------------------	-------

Interfaces

Antenna

Number	2
Connection method	permanently installed
Note on the connection method	MIMO
Gain	5 dBi

Functions

Operating modes	Access Point / Client Adapter / Repeater
Configuration	Web-based management, automated CLI
Quality of service (QoS)	Yes
Security	802.11i
	WPA PSK (preshared key)
	WPA2
	AES
	TKIP
	MAC filter
	Supports 802.1X/RADIUS
Wireless licenses	USA, Canada
Country support	USA
	Canada

Ethernet (RJ45)

Number of interfaces	1
Connection method	RJ45
Note on the connection method	Auto negotiation and autocrossing
Transmission speed	10/100 Mbps
Transmission physics	Copper
Transmission length	100 m (per segment)
No. of channels	1 (RJ45 ports)

Wireless

Designation	Wireless LAN
Antenna connection method	(Internal)
Frequency band	2.4 GHz
	5 GHz
Wireless standard	WLAN
	IEEE 802.11
	a
	b
	g
	n
Transmission power	max. 20 dBm (EIRP)

FL WLAN 1101 - Wireless module

2702538

<https://www.phoenixcontact.com/in/products/2702538>

Number of wireless interfaces	1 IEEE 802. 11 a/b/g/n
Wireless modules that can be connected	10 (In Access Point mode max. 2 SSIDs)

Dimensions

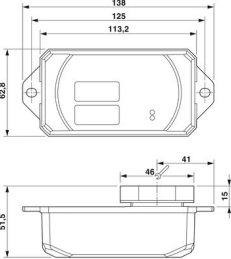
Dimensional drawing	
Width	62.8 mm
Height	36.5 mm
Depth	113.2 mm
Note on dimensions	Outside dimensions

Material specifications

Color	black
Material base plate	Die-cast zinc, nickel-plated
Housing material	Polycarbonate, PC

Environmental and real-life conditions

Ambient conditions

Degree of protection	IP54
Ambient temperature (operation)	0 °C ... 60 °C
Note	Degree of protection when installed
Air pressure (operation)	800 hPa ... 1080 hPa (up to 2000 m above sea level)
Air pressure (storage/transport)	660 hPa ... 1080 hPa (up to 3500 m above sea level)
Ambient temperature (storage/transport)	-40 °C ... 85 °C
Permissible humidity (operation)	5 % ... 95 % (non-condensing)
Permissible humidity (storage/transport)	5 % ... 95 % (non-condensing)

EMC data

Emitted interference

Standards/regulations	FCC/CFR 47, Part 15.107
Test result	Class B

Emitted interference

Standards/regulations	FCC/CFR 47, Part 15.109
Test result	Class A

Emitted interference

Standards/regulations	ICES-003 Issue 6 section 6.1
-----------------------	------------------------------

FL WLAN 1101 - Wireless module



2702538

<https://www.phoenixcontact.com/in/products/2702538>

Test result	Class B
-------------	---------

Emitted interference

Standards/regulations	ICES-003 Issue 6 section 6.2
-----------------------	------------------------------

Test result	Class A
-------------	---------

Mounting

Mounting type	Single-hole mounting
---------------	----------------------

Assembly instructions	Internal antenna
-----------------------	------------------

FL WLAN 1101 - Wireless module

2702538

<https://www.phoenixcontact.com/in/products/2702538>

Drawings

Dimensional drawing

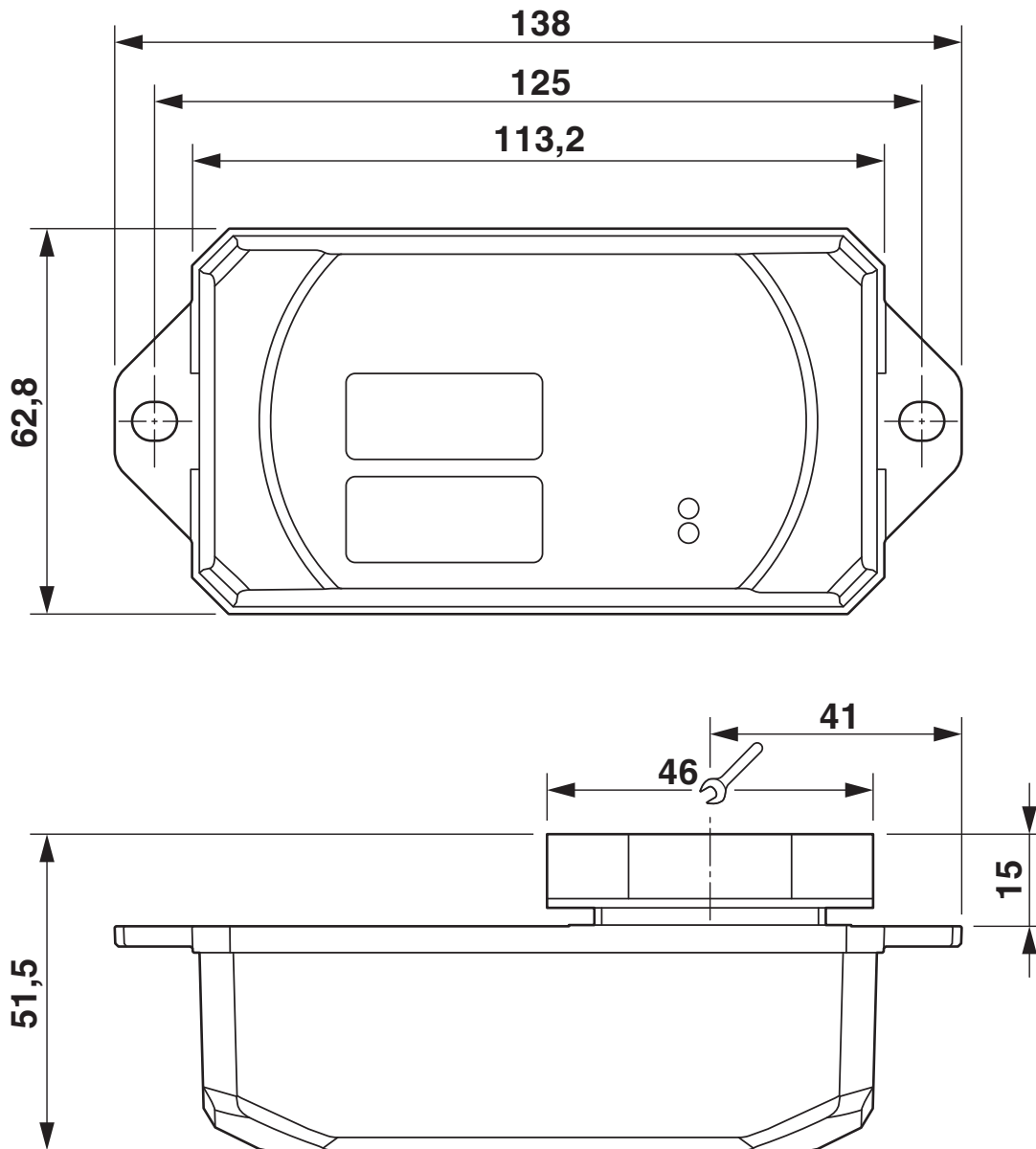

FL WLAN 1101 - Wireless module



2702538

<https://www.phoenixcontact.com/in/products/2702538>

Approvals



cULus Listed

Approval ID: E238705



cULus Listed

Approval ID: E238705



cUL Listed

Approval ID: FILE E 196811



UL Listed

Approval ID: FILE E 196811



UL Listed

Approval ID: FILE E 196811



cUL Listed

Approval ID: FILE E 196811

FL WLAN 1101 - Wireless module



2702538

<https://www.phoenixcontact.com/in/products/2702538>

Classifications

ECLASS

ECLASS-11.0	19170501
ECLASS-12.0	19170501
ECLASS-13.0	19170501

ETIM

ETIM 8.0	EC000816
----------	----------

UNSPSC

UNSPSC 21.0	43222600
-------------	----------

FL WLAN 1101 - Wireless module



2702538

<https://www.phoenixcontact.com/in/products/2702538>

Environmental Product Compliance

REACH SVHC	Lead 7439-92-1
China RoHS	Environmentally Friendly Use Period = 50 years
	For information on hazardous substances, refer to the manufacturer's declaration available under "Downloads"

FL WLAN 1101 - Wireless module



2702538

<https://www.phoenixcontact.com/in/products/2702538>

Accessories

FL M32 ADAPTER - Adapter

2702544

<https://www.phoenixcontact.com/in/products/2702544>



Accessories for FL-WLAN 1100 series: Optional cable feed-through for sealing (IP67) the FL-WLAN 110x connection (IP20), if the device is not directly integrated onto the closed housing. Not needed when mounting on a control cabinet, etc.

CUC-IND-C1ZNI-S/R4IE8 - RJ45 connector

1421607

<https://www.phoenixcontact.com/in/products/1421607>



RJ45 connector, design: RJ45, degree of protection: IP20, number of positions: 8, 1 Gbps, CAT5, material: Metal, connection method: Insulation displacement connection, cable outlet: straight, color: green, Ethernet

FL WLAN 1101 - Wireless module

2702538

<https://www.phoenixcontact.com/in/products/2702538>



FMC 1,5/ 3-STF-3,5 - Printed-circuit board connector

1966101

<https://www.phoenixcontact.com/in/products/1966101>



PCB connector, nominal cross section: 1.5 mm², color: green, nominal current: 8 A, rated voltage (III/2): 160 V, contact surface: Tin, type of contact: Socket, number of potentials: 3, number of rows: 1, number of positions: 3, number of connections: 3, product range: FMC 1,5/..-STF, pitch: 3.5 mm, connection method: Push-in spring connection, conductor/PCB connection direction: 0 °, plug-in system: COMBICON MC 1,5, locking: Screw locking, mounting: Screw flange, type of packaging: packed in cardboard

FL CAT5 PATCH 1,5 - Patch cable

2832221

<https://www.phoenixcontact.com/in/products/2832221>



Patch cable, CAT5, assembled, 1.5 m

Phoenix Contact 2023 © - all rights reserved
<https://www.phoenixcontact.com>

PHOENIX CONTACT (I) Pvt. Ltd.
A-58/2, Okhla Industrial Area, Phase - II, New Delhi-110 020

+91.1275.71420
info@phoenixcontact.co.in