

# QUINT-UPS/ 1AC/ 1AC/500VA - Uninterruptible power supply



2320270

<https://www.phoenixcontact.com/in/products/2320270>

Please be informed that the data shown in this PDF document is generated from our Online Catalog. Please find the complete data in the user documentation. Our General Terms of Use for Downloads are valid.



Uninterruptible power supply with IQ technology 1AC/1AC/500 VA. For 120 V AC/230 V AC applications. Provides information regarding the charging state, remaining runtime, and service life of your rechargeable battery module at all times and thereby increases system availability.

## Product Description

The UPS module for 120 V AC/230 V AC delivers a pure sine curve at the output. For 400 W/500 VA of power, only one energy storage is required, the power supply is already integrated.

## Your advantages

- Optimum use of the buffer time and preventive monitoring of the energy storage
- Can be used worldwide
- Maximum efficiency
- Comprehensive signaling and parameterization
- Simplified startup

## Commercial Data

Item number	2320270
Packing unit	1 pc
Minimum order quantity	1 pc
Sales Key	CMU
Product Key	CMUQ15
Catalog Page	Page 330 (C-4-2019)
GTIN	4046356560078
Weight per Piece (including packing)	2,510 g
Weight per Piece (excluding packing)	2,244 g
Customs tariff number	85371091
Country of origin	DE

# QUINT-UPS/ 1AC/ 1AC/500VA - Uninterruptible power supply



2320270

<https://www.phoenixcontact.com/in/products/2320270>

## Technical Data

### Input data

#### AC operation

Input voltage	240 V AC
	100 V AC
	120 V AC -20 % / +15 %
	230 V AC -20 % / +15 %
Nominal input voltage range	100 V AC ... 240 V AC
Input voltage range	184 V AC ... 264 V AC
	96 V AC ... 138 V AC
	96 V AC ... 264 V AC
Input voltage range AC	196 V AC ... 264 V AC
	102 V AC ... 138 V AC
	96 V AC ... 264 V AC
Voltage type of supply voltage	AC
Nominal frequency	50 Hz ... 60 Hz
	50 Hz ... 60 Hz
AC frequency range	45 Hz ... 65 Hz
Buffer period	1 h (38 AH)
Current consumption	2.2 A (230 V AC)
	0.18 A (230 V AC)
	0.8 A (230 V AC)
	3.7 A (230 V AC)
	4.3 A (120 V AC)
	0.35 A (120 V AC)
	1.3 A (120 V AC)
6.8 A (120 V AC)	
Fixed backup threshold	Configurable, 10% deviation from nominal input voltage set by default
Variable connect threshold	Can be configured using UPS-CONF software
Power factor (cos phi)	0.8
Device mains fuse	10 A
Permissible backup fuse	B16 230 V AC
	20 A 120 V AC, Listed breaker

#### Digital Control Low-Active (configurable)

Battery-operated start 120 V AC Default	Plug-in bridge (output +24 V DC, 30 mA to input A1)
Battery-operated start 230 V AC Default	Plug-in bridge (output +24 V DC, 30 mA to input A2)

### Output data

Classification according to IEC 62040-3	VFD-SS-311
	> 98 % (Mains operation)

# QUINT-UPS/ 1AC/ 1AC/500VA - Uninterruptible power supply



2320270

<https://www.phoenixcontact.com/in/products/2320270>

Efficiency	> 98 % (120 V AC)
	> 86 % (Battery operation)
Nominal output voltage	120 V AC
	230 V AC
Output voltage range	96 V AC ... 144 V AC
	184 V AC ... 264 V AC
Form of output voltage	Pure sine
Nominal output current ( $I_N$ )	4.3 A (120 V AC, -25°C ... 50°C)
	2.2 A (230 V AC, -25°C ... 40°C)
Output current limit	5.2 A (120 V AC)
	2.7 A (230 V AC)
POWER BOOST ( $I_{Boost}$ )	5.2 A (120 V AC, -25°C ... 40°C)
	2.7 A (230 V AC, -25°C ... 40°C)
Bridging time	3600 s
Derating	> 50 °C ... 70 °C (2.5%/K)
UPS connection in parallel	no
UPS connection in series	no
Output power	516 W
Apparent power	500 VA
Nominal power	400 W
Crest factor	2.8
Switch-over time	< 10 ms
Connection in parallel	no
Connection in series	No

## Mains operation

Nominal output voltage	120 V AC
	230 V AC
Output voltage range	102 V AC ... 138 V AC
	196 V AC ... 264 V AC
Nominal output current ( $I_N$ )	4.3 A (120 V AC)
	2.2 A (230 V AC)
POWER BOOST ( $I_{Boost}$ )	5.2 A
	2.7 A
Permissible backup fuse	AC: 1 x circuit breaker - recommended fuse

## Battery operation

Nominal output voltage	120 V AC
	230 V AC
Nominal output current ( $I_N$ )	2.2 A (230 V AC)
	4.3 A (120 V AC)
POWER BOOST ( $I_{Boost}$ )	2.7 A (230 V AC)
	5.2 A (120 V AC)
Permissible backup fuse	25 A in parallel operation of 3.5 AH and 60 WH
	50 A in parallel operation of 7.2 AH, 12 AH, and 38 AH

# QUINT-UPS/ 1AC/ 1AC/500VA - Uninterruptible power supply



2320270

<https://www.phoenixcontact.com/in/products/2320270>

Buffer period	10 min. (400 W / 7,2 Ah)
---------------	--------------------------

Signal: Alarm

Maximum switching voltage	≤ 30 V DC
Output voltage	24 V (SELV)
Continuous load current	≤ 30 mA

Signal: Battery mode

Maximum switching voltage	≤ 30 V DC
Output voltage	24 V (SELV)
Continuous load current	≤ 30 mA

Signal: POWER BOOST

Maximum switching voltage	≤ 30 V DC
Output voltage	24 V (SELV)
Continuous load current	≤ 30 mA

## Energy storage

Nominal voltage $U_N$	24 V DC
End-of-charge voltage	25 V DC ... 30 V DC (temperature compensated)
Charging current	2 A
Nominal capacity range	3.4 Ah ... 114 Ah (3x 38 Ah)
Battery presence check/time interval	1 min.
Battery presence check (cyclic)	60 s
Energy storage device connection in parallel	yes, 3 (observe line protection)
Energy storage device connection in series	no
IQ technology	Yes
Temperature compensation	42 mV/K (preset)
Temperature compensation (preset)	-42 mV/K
Permissible backup fuse	50 A
Network management	Yes

## Connection data

Input

Connection method	Screw connection
Conductor cross section, rigid min.	1.5 mm <sup>2</sup>
Conductor cross section, rigid max.	6 mm <sup>2</sup>
Conductor cross section flexible min.	1.5 mm <sup>2</sup>
Conductor cross section flexible max.	4 mm <sup>2</sup>
Conductor cross section AWG min.	18
Conductor cross section AWG max.	10
Stripping length	8 mm
Screw thread	M4
Tightening torque, min	0.5 Nm
Tightening torque max	0.6 Nm

# QUINT-UPS/ 1AC/ 1AC/500VA - Uninterruptible power supply



2320270

<https://www.phoenixcontact.com/in/products/2320270>

## Output

Connection method	Screw connection
Conductor cross section, rigid min.	1.5 mm <sup>2</sup>
Conductor cross section, rigid max.	6 mm <sup>2</sup>
Conductor cross section flexible min.	1.5 mm <sup>2</sup>
Conductor cross section flexible max.	4 mm <sup>2</sup>
Conductor cross section AWG min.	18
Conductor cross section AWG max.	10
Stripping length	8 mm
Screw thread	M4
Tightening torque, min	0.5 Nm
Tightening torque max	0.6 Nm

## Signal

Connection method	Screw connection
Conductor cross section, rigid min.	0.2 mm <sup>2</sup>
Conductor cross section, rigid max.	2.5 mm <sup>2</sup>
Conductor cross section flexible min.	0.2 mm <sup>2</sup>
Conductor cross section flexible max.	2.5 mm <sup>2</sup>
Conductor cross section AWG min.	24
Conductor cross section AWG max.	10
Stripping length	8 mm
Screw thread	M4
Tightening torque, min	0.5 Nm
Tightening torque max	0.6 Nm

## Interfaces

Interface	IFS (Interface system data port)
	MINI-USB type B

## Signaling

Types of signaling	LED
	Active switching outputs
	Interface/software

### Signal output: Status indicator 120 V AC

Signalization designation	AC mode of operation
Status display	LED
Note on status display	Static to

### Signal output: Status indicator 230 V AC

Signalization designation	AC mode of operation
Status display	LED
Color	green
Note on status display	Static to

# QUINT-UPS/ 1AC/ 1AC/500VA - Uninterruptible power supply



2320270

<https://www.phoenixcontact.com/in/products/2320270>

Signal output: Transistor output, active

Signalization designation	Alarm
Status display	LED
Color	red
Note on status display	Static to

Signal output: Transistor output, active

Signalization designation	Battery mode
Status display	LED
Color	yellow
Note on status display	Static to

Signal output: Transistor output, active

Signalization designation	POWER BOOST
Status display	LED
Color	yellow
Note on status display	Static to

Signal output

Signalization designation	Battery charge
Status display	Bar graph
Color	red/green

## Electrical properties

Insulation voltage input, output / housing	1.5 kV AC
	2.1 kV DC

## Product properties

Product type	AC UPS
Product family	QUINT AC-USV
IQ technology	Yes
MTBF (IEC 61709, SN 29500)	> 240513 h (40 °C)

Insulation characteristics

Protection class	I
------------------	---

Life expectancy (electrolytic capacitors)

Time	184982 h
------	----------

## Dimensions

Width	125 mm
Height	130 mm
Depth	125 mm

Installation dimensions

Installation distance right/left	5 mm / 5 mm
Installation distance top/bottom	50 mm / 50 mm

# QUINT-UPS/ 1AC/ 1AC/500VA - Uninterruptible power supply



2320270

<https://www.phoenixcontact.com/in/products/2320270>

## Mounting

Mounting type	DIN rail mounting
Assembly instructions	alignable: $P_N \geq 50\%$ , 5 mm horizontally, 15 mm next to active components, 50 mm vertically alignable: $P_N < 50\%$ , 0 mm horizontally, 40 mm vertically top, 20 mm vertically bottom
Mounting position	horizontal DIN rail NS 35, EN 60715

## Material specifications

Color	aluminium
Housing material	Metal
Type of housing	Aluminum (AlMg3)
Hood version	Galvanized sheet steel, free from chrome (VI)
Side element version	Aluminum
Housing material	Steel sheet, zinc-plated

## Environmental and real-life conditions

### Ambient conditions

Degree of protection	IP20
Ambient temperature (operation)	-25 °C ... 70 °C (> 50 °C Derating: 2.5 %/K)
Ambient temperature (storage/transport)	-40 °C ... 85 °C
Ambient temperature (start-up type tested)	-40 °C
Climatic class	3K3 (in acc. with EN 60721)
Max. permissible relative humidity (operation)	≤ 95 % (25 °C, non-condensing)
Shock	18 ms, 30g, in each space direction (according to IEC 60068-2-27)
Vibration (operation)	< 15 Hz, amplitude ±2.5 mm (according to IEC 60068-2-6) 15 Hz ... 150 Hz, 2.3g $t_v = 90$ min.

## Standards and regulations

Rail applications	EN 50121-4
-------------------	------------

### Standards

Standard uninterruptible power supply systems	EN 62040-1
---	------------

### Uninterruptible power supply systems

Standards/specifications	EN 62040-1
--------------------------	------------

## Approvals

### UL

Identification	UL/C-UL Recognized UL 1778
----------------	----------------------------

## EMC data

Low Voltage Directive	Conformance with Low Voltage Directive 2014/35/EC
Interference emission	Noise emission in accordance with EN 62040-2

# QUINT-UPS/ 1AC/ 1AC/500VA - Uninterruptible power supply



2320270

<https://www.phoenixcontact.com/in/products/2320270>

Noise immunity	Immunity in accordance with EN 62040-2
Electromagnetic compatibility	Conformance with EMC Directive 2014/30/EU

## Electrostatic discharge

Standards/regulations	EN 61000-4-2
-----------------------	--------------

## Electrostatic discharge

Contact discharge	8 kV (Test Level 4)
Discharge in air	15 kV (Test Level 4)
Comments	Criterion A

## Electromagnetic HF field

Standards/regulations	EN 61000-4-3
-----------------------	--------------

## Electromagnetic HF field

Frequency range	80 MHz ... 3 GHz
Test field strength	10 V/m
Frequency range	1 GHz ... 3 GHz
Test field strength	10 V/m
Frequency range	2 GHz ... 3 GHz
Test field strength	3 V/m
Comments	Criterion A

## Fast transients (burst)

Standards/regulations	EN 61000-4-4
-----------------------	--------------

## Fast transients (burst)

Input	2 kV (Test Level 3 - asymmetrical)
Output	2 kV (Test Level 3 - asymmetrical)
Signal	2 kV (Test Level 4 - asymmetrical)
Comments	Criterion A

## Surge voltage load (surge)

Standards/regulations	EN 61000-4-5
Input	1 kV (Test Level 2 - symmetrical)
	2 kV (Test Level 3 - asymmetrical)
Output	1 kV (Test Level 2 - symmetrical)
	2 kV (Test Level 3 - asymmetrical)
Comments	Criterion A

## Conducted interference

Standards/regulations	EN 61000-4-6
-----------------------	--------------

## Conducted interference

I/O/S	asymmetrical
Frequency range	0.15 MHz ... 80 MHz
Comments	Criterion A
Voltage	10 V (Test Level 3)



# QUINT-UPS/ 1AC/ 1AC/500VA - Uninterruptible power supply



2320270

<https://www.phoenixcontact.com/in/products/2320270>

## Emitted interference

Radio interference voltage	EN 62040-2 (Class C1)
----------------------------	-----------------------

## Criteria

Criterion A	Normal operating behavior within the specified limits.
Criterion B	Temporary impairment to operational behavior that is corrected by the device itself.

# QUINT-UPS/ 1AC/ 1AC/500VA - Uninterruptible power supply



2320270

<https://www.phoenixcontact.com/in/products/2320270>

## Drawings

Block diagram

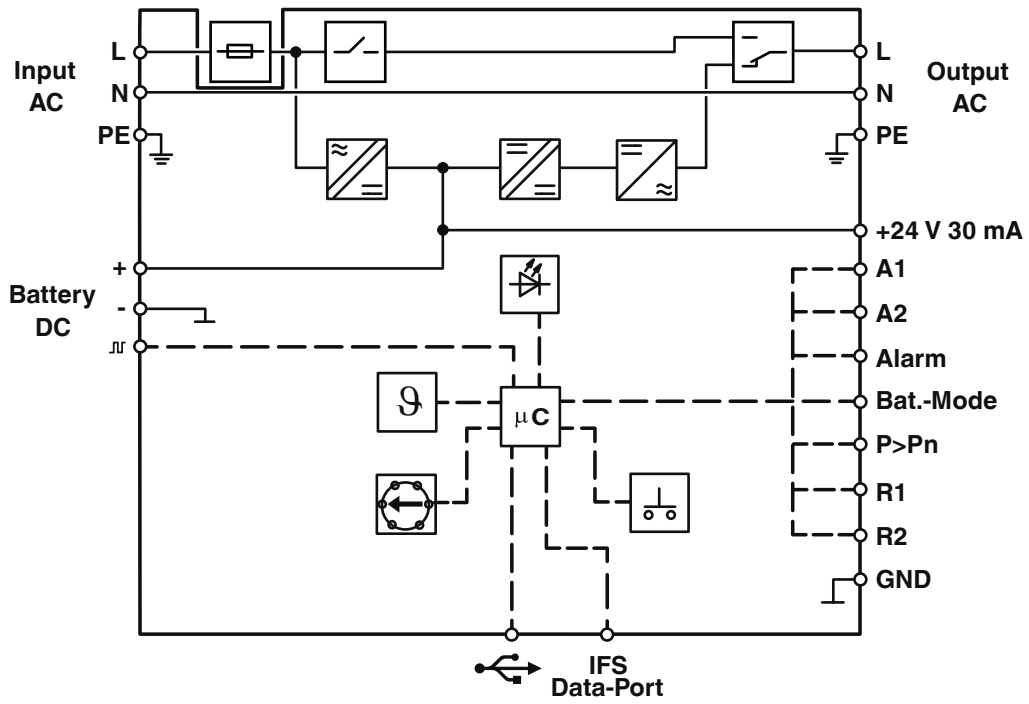

# QUINT-UPS/ 1AC/ 1AC/500VA - Uninterruptible power supply



2320270

<https://www.phoenixcontact.com/in/products/2320270>

## Approvals



**cUL Recognized**  
Approval ID: FILE E 342453



**UL Recognized**  
Approval ID: FILE E 342453



**IECEE CB Scheme**  
Approval ID: SI-7771



**EAC**  
Approval ID: EAC-Zulassung



**EAC**  
Approval ID: EAC-Zulassung



**EAC**  
Approval ID: RU S-DE.BL08.W.00764



**KC**  
Approval ID: R-R-PCK-2320270



**UL Recognized**  
Approval ID: FILE E 342453



**IECEE CB Scheme**  
Approval ID: SI-7771



**cUL Recognized**  
Approval ID: FILE E 342453



**EAC**  
Approval ID: RU S-DE.BL08.W.00764



**KC**  
Approval ID: R-R-PCK-2320270

# QUINT-UPS/ 1AC/ 1AC/500VA - Uninterruptible power supply



2320270

<https://www.phoenixcontact.com/in/products/2320270>



**EAC**

Approval ID: RU-DE.B.00184/20



**EAC**

Approval ID: RU-DE.B.00184/20



**cUL Recognized**

Approval ID: FILE E 359066



**UL Recognized**

Approval ID: FILE E 359066



**cUL Recognized**

Approval ID: FILE E 359066



**UL Recognized**

Approval ID: FILE E 359066

# QUINT-UPS/ 1AC/ 1AC/500VA - Uninterruptible power supply



2320270

<https://www.phoenixcontact.com/in/products/2320270>

## Classifications

### ECLASS

ECLASS-11.0	27040705
ECLASS-13.0	27040705
ECLASS-12.0	27040705

### ETIM

ETIM 8.0	EC000382
----------	----------

### UNSPSC

UNSPSC 21.0	39121000
-------------	----------

# QUINT-UPS/ 1AC/ 1AC/500VA - Uninterruptible power supply



2320270

<https://www.phoenixcontact.com/in/products/2320270>

## Environmental Product Compliance

China RoHS	Environmentally friendly use period: unlimited = EFUP-e
	No hazardous substances above threshold values

# QUINT-UPS/ 1AC/ 1AC/500VA - Uninterruptible power supply



2320270

<https://www.phoenixcontact.com/in/products/2320270>

## Accessories

### UPS-BAT/PB/24DC/4AH - Energy storage

1274117

<https://www.phoenixcontact.com/in/products/1274117>



Energy storage, VRLA-AGM, 24 V DC, 4 Ah, automatic detection and communication with QUINT UPS-IQ

---

### UPS-BAT/PB/24DC/7AH - Energy storage

1274118

<https://www.phoenixcontact.com/in/products/1274118>



Energy storage, VRLA-AGM, 24 V DC, 7 Ah, automatic detection and communication with QUINT UPS-IQ

# QUINT-UPS/ 1AC/ 1AC/500VA - Uninterruptible power supply



2320270

<https://www.phoenixcontact.com/in/products/2320270>

## UPS-BAT/PB/24DC/12AH - Energy storage

1274119

<https://www.phoenixcontact.com/in/products/1274119>



Energy storage, VRLA-AGM, 24 V DC, 12 Ah, automatic detection and communication with QUINT UPS-IQ

---

## UPS-BAT/PB/24DC/20AH - Energy storage

1348516

<https://www.phoenixcontact.com/in/products/1348516>



Energy storage, VRLA-AGM, 24 V DC, 20 Ah, automatic detection and communication with QUINT UPS-IQ



# QUINT-UPS/ 1AC/ 1AC/500VA - Uninterruptible power supply



2320270

<https://www.phoenixcontact.com/in/products/2320270>

## UPS-BAT/PB/24DC/40AH - Energy storage

1354641

<https://www.phoenixcontact.com/in/products/1354641>



Energy storage, VRLA-AGM, 24 V DC, 40 Ah, automatic detection and communication with QUINT UPS-IQ

---

## UPS-BAT/LI/24DC/128WH - Energy storage

1396415

<https://www.phoenixcontact.com/in/products/1396415>



Energy storage, Lithium-Ion (LiFePO<sub>4</sub>), 24 V DC, 128 Wh. For use with a QUINT UPS for ambient temperatures (charging) of 0°C ... 60°C and a maximum charging current of 5 A. For charging below 0°C, please note the permissible UPS V/C level.

# QUINT-UPS/ 1AC/ 1AC/500VA - Uninterruptible power supply



2320270

<https://www.phoenixcontact.com/in/products/2320270>

## UPS-BAT/VRLA-WTR/24DC/13AH - Energy storage

2320416

<https://www.phoenixcontact.com/in/products/2320416>



Energy storage device, lead AGM, VRLA technology, 24 V DC, 13 Ah, tool-free battery replacement, automatic detection, and communication with QUINT UPS-IQ

---

## UPS-BAT/VRLA-WTR/24DC/26AH - Energy storage

2320429

<https://www.phoenixcontact.com/in/products/2320429>



Energy storage device, lead AGM, VRLA technology, 24 V DC, 26 Ah, tool-free battery replacement, automatic detection, and communication with QUINT UPS-IQ

# QUINT-UPS/ 1AC/ 1AC/500VA - Uninterruptible power supply



2320270

<https://www.phoenixcontact.com/in/products/2320270>

## UPS-CAP/24DC/20A/20KJ - Energy storage

2320380

<https://www.phoenixcontact.com/in/products/2320380>



Maintenance-free energy storage based on double-layer capacitor, 24 V DC, 20 kJ, automatic detection and communication with QUINT UPS-IQ

---

## CABLE-USB/MINI-USB-3,0M - USB cable

2986135

<https://www.phoenixcontact.com/in/products/2986135>

USB connecting cable: USB plug type A to USB plug type Mini-B; length: 3 m



# QUINT-UPS/ 1AC/ 1AC/500VA - Uninterruptible power supply



2320270

<https://www.phoenixcontact.com/in/products/2320270>

## IFS-MINI-DIN-DATACABLE - Data cable

2320487

<https://www.phoenixcontact.com/in/products/2320487>



Data cable for communication, e.g., between Phoenix Contact type ILC 1x Inline controllers and Phoenix Contact devices with the 12-pos. IFS data port, such as QUINT UPS-IQ UPS or TRIO UPS

---

## IFS-RS232-DATACABLE - Data cable

2320490

<https://www.phoenixcontact.com/in/products/2320490>



Data cable for communication between devices with a D-SUB 9 RS-232 connection and Phoenix Contact devices with the 12-pos. IFS data port such as QUINT UPS-IQ or TRIO UPS.

# QUINT-UPS/ 1AC/ 1AC/500VA - Uninterruptible power supply



2320270

<https://www.phoenixcontact.com/in/products/2320270>

## IFS-USB-DATACABLE - Data cable

2320500

<https://www.phoenixcontact.com/in/products/2320500>

Used for communicating between industrial PCs and Phoenix Contact devices with the 12-pos. IFS data port, such as QUINT UPS or TRIO UPS.



---

## UWA 130 - Mounting adapter

2901664

<https://www.phoenixcontact.com/in/products/2901664>

2-piece universal wall adapter for securely mounting the device in the event of strong vibrations. The profiles that are screwed onto the side of the device are screwed directly onto the mounting surface. The universal wall adapter is attached on the left/right.



# QUINT-UPS/ 1AC/ 1AC/500VA - Uninterruptible power supply



2320270

<https://www.phoenixcontact.com/in/products/2320270>

## UWA 182/52 - Mounting adapter

2938235

<https://www.phoenixcontact.com/in/products/2938235>



Universal wall adapter for securely mounting the device in the event of strong vibrations. The device is screwed directly onto the mounting surface. The universal wall adapter is attached on the top/bottom.

---

## FUSE 10A/400V GRL - Fuse

2908358

<https://www.phoenixcontact.com/in/products/2908358>



Fuse, nominal current: 10 A, length: 31.8 mm, diameter: 6.35 mm

# QUINT-UPS/ 1AC/ 1AC/500VA - Uninterruptible power supply



2320270

<https://www.phoenixcontact.com/in/products/2320270>

## IFS-CONFSTICK - Memory block

2986122

<https://www.phoenixcontact.com/in/products/2986122>



Multi-functional memory block for the INTERFACE system for easy storage and backup of the configuration.

---

## IFS-CONFSTICK-L - Memory block

2901103

<https://www.phoenixcontact.com/in/products/2901103>



Multi-functional memory block with handle for the INTERFACE system; for easy storage and back up of the configuration.

---

Phoenix Contact 2023 © - all rights reserved  
<https://www.phoenixcontact.com>

PHOENIX CONTACT (I) Pvt. Ltd.  
A-58/2, Okhla Industrial Area, Phase - II, New Delhi-110 020

+91.1275.71420  
[info@phoenixcontact.co.in](mailto:info@phoenixcontact.co.in)