

Solid-state Timer

# H3YN-41-Z-B DC24

Solid-state Timer, Four-mode multi, Output: 4PDT, Twin contacts, Long-time range model, Plug-in terminal (14-pin), Black, 24 VDC



Image

<b>Rated power supply voltage</b>	24 VDC If power supply incorporates a single-phase full-wave rectifier.
<b>Control output (Type)</b>	Time-limit: 4PDT
<b>Connecting method</b>	14-pin round socket (Push-In Plus Terminal Block)

Ratings/Specifications

As of December 23, 2024

<b>Rated power supply voltage</b>	24 VDC If power supply incorporates a single-phase full-wave rectifier.
<b>Allowable voltage variable range</b>	85 to 110% of the power supply voltage
<b>Power consumption</b>	Relay ON: Approx. 1.1 W (at 24 VDC)/Relay OFF: Approx. 0.1 W (at 24 VDC)
<b>Reset voltage</b>	10% max. of rated supply voltage
<b>Number of time ranges</b>	4
<b>Operation mode</b>	ON delay, Interval, Flicker OFF start, Flicker ON start
<b>Control output (Type)</b>	Time-limit: 4PDT
<b>Control output (Contact output)</b>	Resistive load: 3 A at 250 VAC (cosφ=1) Minimum applicable load: 0.1 mA at 1 VDC (failure level: P)
<b>Ambient temperature range</b>	Operating: -10 to 55 °C (with no icing) Storage: -25 to 65 °C (with no icing)
<b>Ambient humidity range</b>	Operating: 35 to 85 %
<b>Accuracy of operating time</b>	±1% FS max.
<b>Setting error</b>	±10% FS ±50 ms max.
<b>Reset time</b>	0.1 s max. (including halfway reset)
<b>Influence of voltage</b>	±2% FS max.
<b>Influence of temperature</b>	±2% FS max.
<b>Insulation resistance</b>	100 MΩ min. (at 500 VDC)
<b>Dielectric strength</b>	Between current carrying terminals and exposed non-current carrying metal parts: 2000 VAC 50/60 Hz 1 min (Terminal screw sections are not excluded) Between operating power circuit and control output: 2,000 VAC 50/60 Hz 1 min Between contacts of different polarity: 1,500 VAC 50/60 Hz 1 min Between non-continuous contacts: 1,000 VAC 50/60 Hz 1 min

<b>Impulse withstand voltage</b>	Between power terminals: 1 kV Between current carrying terminals and exposed non-current carrying metal parts: 1.5 kV
<b>Noise immunity</b>	±1.5 kV square-wave noise by noise simulator (pulse width: 100 ns/1 μs, 1-ns rise)
<b>Static immunity</b>	Multifunction: 4 kV, Destruction: 8 kV
<b>Vibration resistance</b>	Destruction: 10 to 55 Hz, 0.75 mm single amplitude each in 3 directions for 1 hour Malfunction: 10 to 55 Hz, 0.5 mm single amplitude each in 3 directions for 10 min
<b>Shock resistance</b>	Destruction: 1,000 m/s <sup>2</sup> , 3 times each in 6 directions Malfunction: 100 m/s <sup>2</sup> , 3 times each in 6 directions
<b>Life expectancy (relay output)</b>	Electrical: 100,000 operations min. (3 A at 250 VAC, resistive load at 1800 operations/h, Room temperature) Mechanical: 10 million operations min. (under no load at 1,800 operations/h)
<b>Degree of protection</b>	IP40
<b>Connecting method</b>	14-pin round socket (Push-In Plus Terminal Block)
<b>Case color</b>	Black
<b>Weight</b>	Approx. 50 g
<b>Applicable socket</b>	PYF-14-PU-L

As of December 23, 2024

### Dimensions

As of December 23, 2024

Outline drawing

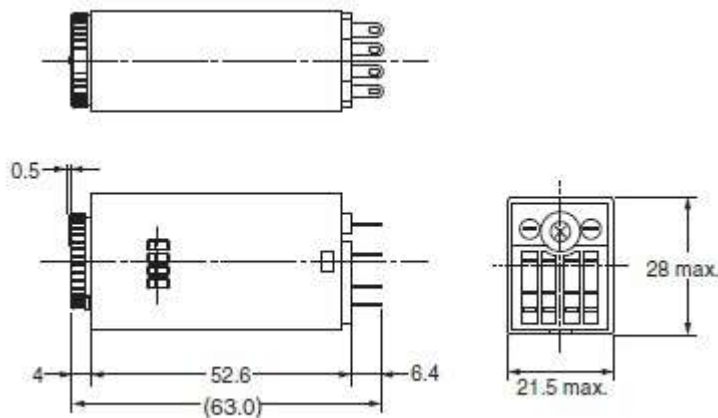

As of December 23, 2024

### Internal connection

As of December 23, 2024

Internal connection

**H3YN-4-B/-41-B**  
**H3YN-4-Z-B/-41-Z-B**

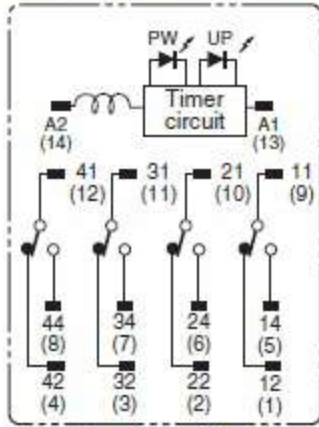

**(Bottom View)**

**(DIN Indication)**

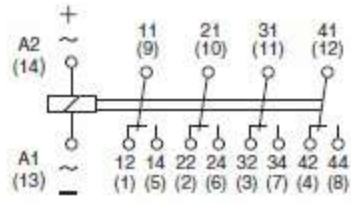

As of December 23, 2024

Operating chart

As of December 23, 2024

Operating chart

# Timing Chart

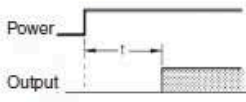
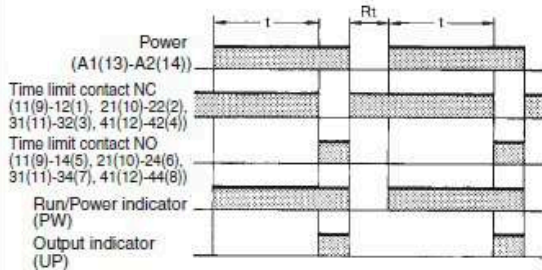
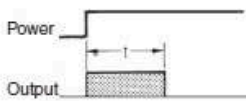
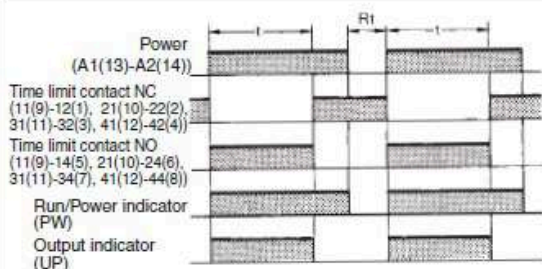
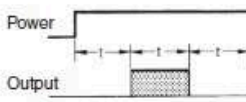
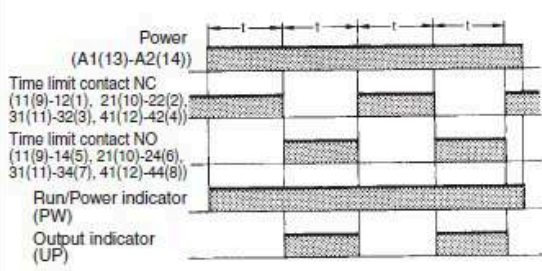
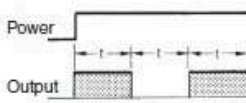
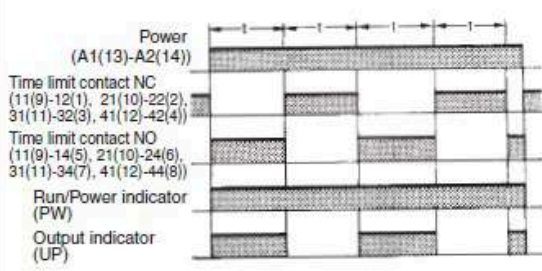
Operating mode	Timing chart	
	H3YN-4-B/-41-B	
<b>ON-delay</b> 		
<b>Interval</b> 		
<b>Flicker OFF-start</b> 		
<b>Flicker ON-start</b> 		

**Note:** t: Set time  
Rt: Reset time