

Oil-resistant Limit Switch

D4ER-2C21N-DTK1EJ



Image

Oil-resistant Limit Switch, Plunger, 0.1 A at 30 VDC, Right-hand cable, Pre-wired connector

Shape/Structure	Enclosed Limit switches
Actuator	Plunger
Electrical ratings	0.1 A at 30 VDC
Contact form	SPDT
Cable specifications	Oil-resistant cable, 0.3 m

Ratings / Performance

As of August 8, 2024

Shape/Structure	Enclosed Limit switches
Actuator	Plunger 7.8 dia. Stainless steel plunger
Electrical ratings	0.1 A at 30 VDC
Contact form	SPDT
Load	Micro load
Ratings (DC): Non-Inductive load	Resistive load: 0.1 A at 8 VDC/0.1 A at 14 VDC/0.1 A at 30 VDC
Cable specifications	Oil-resistant cable, 0.3 m Location of lead output: Right-hand
Ambient temperature	Operating: 5 to 70 °C (with no freezing or condensation) Storage: 5 to 70 °C (with no freezing or condensation)
Ambient humidity	35 to 95 % (with no condensation)

Permissible operating speed	0.1 mm/s to 0.5 m/s
Permissible operating frequency	Electrical: 30 operations / 1 minute max. Mechanical: 120 operations / 1 minute max.
Contact resistance (Initial value)	50 mΩ max. (initial value for the built-in switch when tested alone)
Insulation resistance	100 MΩ min. (at 500 VDC)
Dielectric strength	Between each terminal of the same polarities: 1,000 VAC 50/60 Hz 1 min Between each terminal and non-live-metallic part: 1,500 VAC 50/60 Hz 1 min
Impulse withstand voltage	Between each terminal and non-live-metallic part: 2.5 kV
Durability	Mechanical: 4,000,000 operations min.
Vibration resistance	Malfunction: 10 to 55 Hz, 1.5 mm double amplitude

Shock resistance	Destruction: 1,000 m/s ² max. Malfunction: 300 m/s ² max.
Classification of protection against electric shock	Class II (Grounding not required with double) insulation

Operating Force (OF)	Standard value 11.77 N max.
Release Force (RF)	Standard value 4.9 N min.
Pre-Travel (PT)	Standard value 1.5 mm max.
Movement Differential (MD)	Reference value 0.1 mm
Over-Travel (OT)	Standard value 3 mm min.
Operating Position (OP)	Standard value 25.4±0.8 mm

As of August 8, 2024

Dimensions

As of August 8, 2024

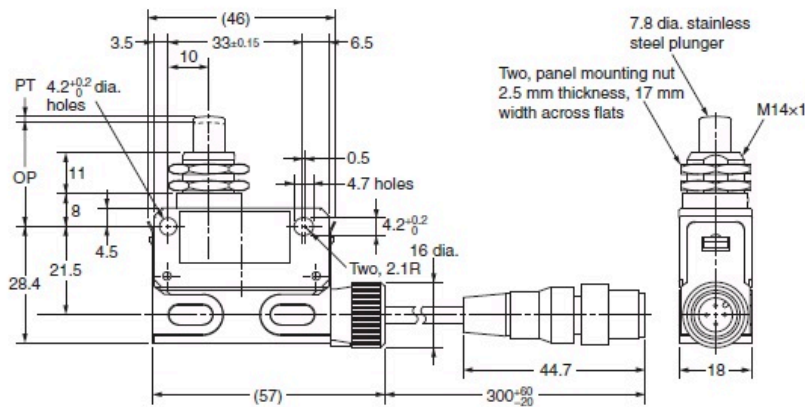

As of August 8, 2024

Circuits configuration

As of August 8, 2024

Connector pin arrangement

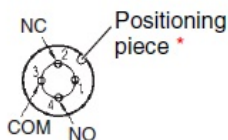

* The position of the positioning piece is not always the same. If using an L-shaped connector causes problems in application, use a straight connector.

